

OWNER'S HANDBOOK
FOR
BUKH MARINE DIESEL
LIFEBOAT ENGINE
TYPE DV36 ME



powering **marine** safety

BUKH A/S
Aabenraavej 13 - 17
DK - 6340 Krusaa
Tel: +45 74 62 20 88
Fax: +45 74 62 74 07
E-mail: bukh@bukh.dk
www.bukh.dk

CONTENTS

	Page
Pictures for recognition of engine	3
Introduction	4
Standard equipment.....	4
Operating manual.....	4
Preparation for the first start.....	5
Before start.....	5
Electric start	5
Hand start.....	5
After start.....	6
Maneuvering	6
Stopping the engine	6
Running in	6
Maintenance.....	6
Belt for alternator.....	6
Air inlet filter	6
Fuel filter.....	6
Fuel lift pump.....	7
Lubricating oil system.....	7
Change of oil	7
Recommended lubricating oil	7
Change of lubricating oil filter.....	7
Cooling water system.....	7
Seawater cooling.....	7
Exchange of zinc anode.....	7
Exchange of impeller.....	7
Freshwater cooling.....	8
Frost precautions	8
Electrical system	8
Marine gear	8
Propeller equipment.....	9
Sail drive.....	9
Galvanic corrosion	10
Starting instructions.....	10
Winter storage of the engine.....	11
Technical data for engine and gearbox.....	12
Recommended maintenance and checklist	13
Irregular operation	14
Lubricating oil chart.....	15
EI-diagram	16
DV36 installation.. ..	17
List of representatives	18
General Terms of Sale and Delivery.....	22

1. Lubricating oil filling plug
2. Valve cover
3. Electric stop solenoid
4. Air filter with noise suppression
5. Fuel filter
6. Cooling water drain plug
7. Dipstick for engine oil
8. Oil pressure switch
9. Lubricating oil filter
10. Fuel pump
11. Control lever
12. Cock
13. Reversing lever for gear
14. Bracket for reversing cable
15. Coupling flange for propeller shaft
16. Reverse-reduction gear
17. Housing for vacuum valve
18. Bilge pump for change of lub. oil
19. Bracket for control cable
20. Electric multi plug
21. Fuel lift pump
22. Lifting fittings
23. Water cooled exhaust manifold
24. Zinc anode
25. Cooling water expansion tank
26. Cooling water filling plug
27. Identification label
28. Water drain plug for exhaust manifold
29. Thermostat housing
30. Cooling water temperature transmitter
31. Exhaust
32. Outlet to keelcooler
33. Circulation pump
34. Dip stick for gear oil
35. Reversible engine mountings
36. Lubricating oil cooler
37. Electric starter
38. Inlet from keel cooler
39. Flywheel
40. Tension device for V-belt
41. Alternator

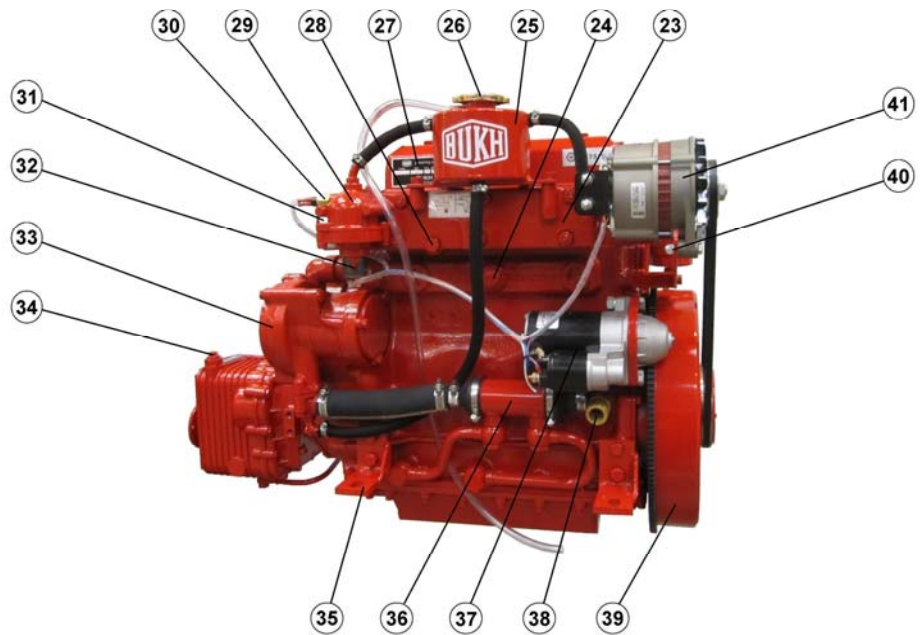
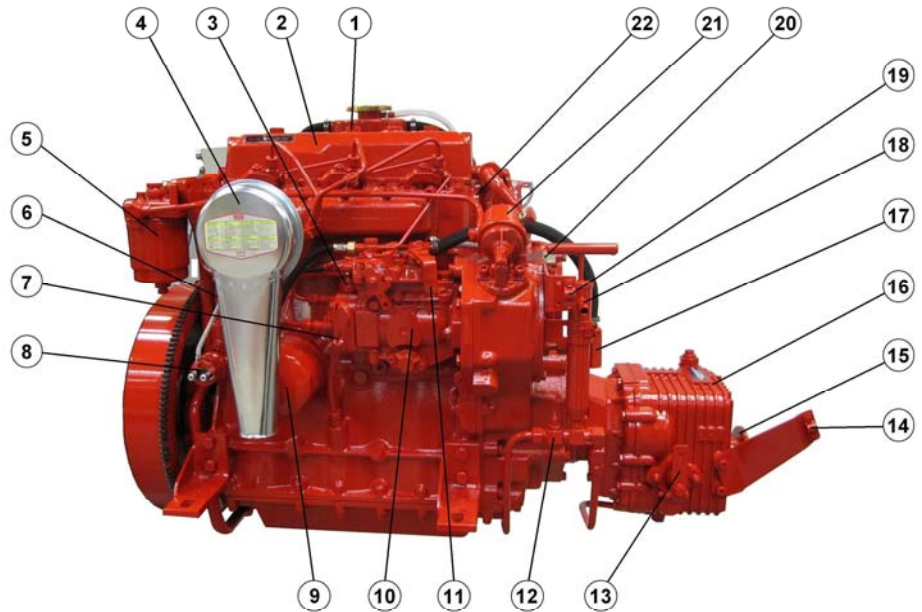

INTRODUCTION

BASIC ENGINE CONFIGURATION:

The BUKH Marine Diesel engine is a four-stroke marine diesel engine with direct fuel injection and the following basic equipment:

Crankcase with oil pan, one-piece cylinder head with 2 valves per cylinder, forged crankshaft with counterweights, balance weights, cast iron connecting rods, light metal pistons, water-cooled exhaust manifold; all necessary pipework for exhaust, coolant, fuel and lubricating oil are fitted on engine.

A reverse/reduction gearbox with integrated thrust bearing is fitted on the engine.

No BUKH Diesel Engine is sent from the factory without having been thoroughly tested.

The tests have shown that the engine in all aspects is working satisfactorily and is generating its full power.

You will expect the engine to work reliably without giving any problems, and to achieve this you are asked to follow the instructions in this manual. By so doing, you will get the best from your BUKH engine.

If a problem with the engine should arise, we ask you to apply to one of our distributors, who will always be ready to help you, having skilled personnel, necessary tools etc., and at the same time you will be sure that only original BUKH spare parts are used.

Do always use original BUKH spare parts.

When ordering spare parts from the distributor please state:

Engine type and serial number, description and number of parts.

BUKH A/S
Powering Marine Safety

As BUKH A/S is always endeavouring to improve the engines, the specifications mentioned are subject to alterations without previous notice.

Read this instruction book thoroughly before starting your new BUKH Diesel Engine.

STANDARD EQUIPMENT for DV36ME

Reverse-reduction gear
Decompression lever
Wet sump lubrication oil system
Full-flow lubrication oil filter
Automatic injection timing
Centrifugal governor
Watercooled exhaust manifold
Air inlet filter and silencer
Fuel lift pump
Electric start
Charging alternator
Operating remote panel with:
a) Charging light

b) Lub. oil pressure warning light
c) Cooling water temp. warning light
d) Key switch for start and stop
e) Audible warning
Fittings for remote control
Standard set of tools
Drain pump for lub. oil (built on engine)
Following documentation is delivered with the engine:
1. Operating manual with sparepart katalog
2. Test certificate
Flex. engine mounts (optional)
Stern gear (optional)
Raised hand start (optional)

OPERATING MANUAL

Before the engine is put into use you are recommended to get familiar with the placing of the following components of engine and gear:

Fuel oil filter, lub oil filter and air intake filter, fuel lift pump with handle, zincrod in the crankcase and water-separator in the fuel pipe (if mounted).

Where is lub oil poured into engine and gear and where are the dipsticks placed? Where is fuel oil filled into the fuel tank and where is the drain placed? Where is the main switch?

Preparation before first start

1. Pour lubricating oil through filling hole on top of valve cover.
Check that oil level is between the marks on the dipstick, placed at the port side of the engine.
Check oil level as mentioned below:
 - a) remove and wipe dipstick
 - b) reinsert dipstick in the pipe
 - c) withdraw dipstick, check oil level.
2. Pour lubricating oil through dipstick hole on the top of reverse- and reduction gear and check oil level as described in pos 1.
3. Flexible sterntube: Lubricate the stuffing box with sterntube oil (outboard).
Unscrew the filler plug and pour in oil until the bearing is full.
Important: The stuffing box shall under no circumstances be force-lubricated.
These instructions are only valid for propeller equipment supplied by BUKH.
If other equipment is mounted, we refer to the instructions given for this.
4. We always recommend checking of oil level before start.
5. Fill the fuel tank.
6. Bleed the fuel system in the following way:
 - a) Loosen the slotted screw B on the fuel filter and pump with the handle A on the fuel lift pump until the fuel is free from air bubbles and runs out at the slotted screw.
 - b) Tighten the slotted screw B and continue pumping with the handle A until fuel, free from bubbles, runs through the transparent hose from fuel pump to tank.
You must lock the pumping handle in the upper position when you have finished pumping.
 - c) Loosen the fuel pressure pipes at their connection on the fuel valves and turn the engine by the starter motor until fuel, free from bubbles, runs out from the fuel pressure pipes. Finally tighten the pipes and the engine fuel system is ready for use.

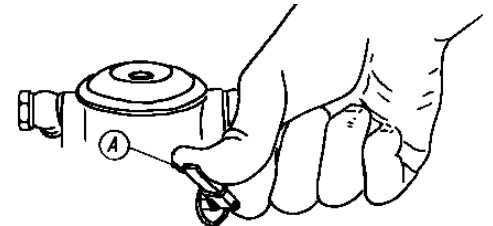
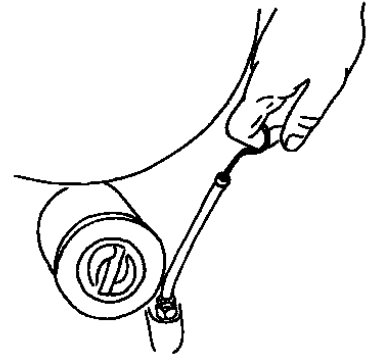
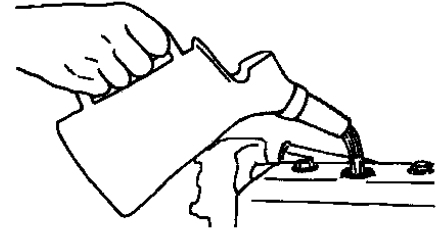

Normally it will not be necessary to bleed the fuel system before starting but after changing the fuel filter element or carrying out any work on the fuel system it should be bled in the following way: Loosen the bleed screw and operate the hand priming lever on the fuel lift pump until air-free fuel discharges from screw. Tighten bleed screw. Loosen high pressure pipe unions to injectors and turn engine until fuel discharges from pipes. Reconnect pipes to injectors. The engine will start in the normal way.

AFTER THE ENGINE HAS BEEN TAKEN INTO USE

Before start

1. The oil level of the engine should be checked every 14 days or every 25 hours of running as described in "Preparation before first start". It is not necessary to refill oil if the level is between the two marks on the dipstick.
2. The oil level of the reduction gear should be checked every 14 days or every 25 hours of running as described in "Preparation before first start".
3. The sterntube stuffing box should be lubricated every 14 days or every 25 hours of running.
4. Check the quantity of fuel in the tank.

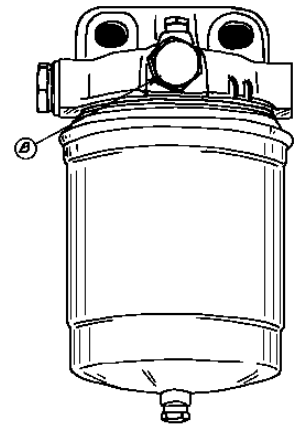

Electric start with remote control and instrument panel

1. Switch on the main switch.
2. Put the marine gear in neutral position by means of the control handle.
3. The engine is started by pushing the key and turning it to the right.
The starter should not work for more than 10-15 secs. continuously.

Hand start (optional)

1. Put the gear lever in neutral position.
2. Turn decompression lever on valve cover anti-clockwise as far as possible.
3. Engage starting handle and crank engine as quickly as possible. Release decompression lever quickly by turning lever clockwise while cranking and engine will start.
4. By hand start in cold weather you may achieve an easier start after having cranked the engine with activated decompression lever before the starting procedure.

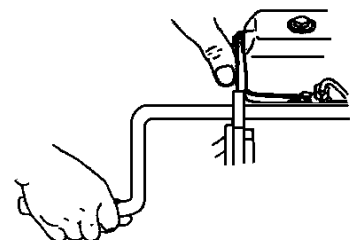

Never accelerate a cold engine. Let it get warm first.

OPERATING MANUAL FOR BUKH DV36ME ENGINES

After Start

1. When the engine has started, the RPM should be 900-1000 RPM when idling.
2. Check the oil pressure. Normally this should be 2-4.5 bar. With cold engine the RPM should be kept down so that the oil pressure does not exceed 4.5 bar. When idling at warm engine the oil pressure must not be below 1 bar.
3. Immediately after start the oil pressure warning lamp should go out. During normal operation the lamp should stay off.
4. Make sure that the charging control lamp goes out after the engine has started.
5. Check the cooling water temperature frequently. The temperature should be in the area of 70 – 95°C when engine is warm.

Manoeuvring

1. With the control lever in central position the engine is idling, and the marine gear is in neutral (pos. 0). When the lever is moved forward in range 1, the marine gear is engaged to "Ahead" first, and then in range 2 the engine R.P.M. is increased. When the lever is moved from the central position to range 3, the marine gear is engaged to "Astern" first, and then in range 4 the engine R.P.M. is increased.
2. Only engage "Ahead" or "Astern" when the engine is idling.
3. To accelerate engine without engaging gear, operate gear release button 5 and move control handle in either direction.
4. Increase the load gradually from idling in the course of the first 15-20 minutes shortly after the start of the engine.

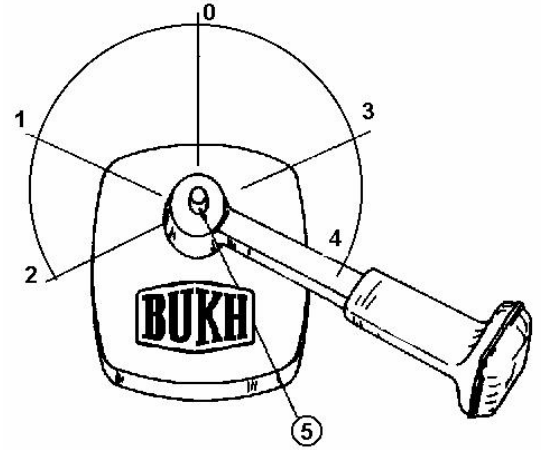

0. Idling in neutral position
1. Idling, gear in "Ahead" position
2. Gear "Ahead" position, increasing RPM.
3. Idling, gear in "Astern" position
4. Gear in "Astern" position, increasing RPM.
5. Gear release button

Stopping the engine

1. Reduce the load gradually in the course of 15-20 minutes before stop.
2. Reduce the engine to idling and put the gear in neutral position.
3. Turn the ignition key left to stop position, pushing it slightly inwards. The key must not be left in this position after the engine has stopped due to the large current consumption of the stop solenoid. In this position the acoustic alarm will function, when the engine has stopped.
4. Turn off the battery main switch.

Running in

To secure long life and maximum power it is recommended to run the engine for the first 25 hours at not more than 80 pct. of the maximum output (about 3200 r.p.m.)

You should avoid slow hauling as for instance towage. After the first 25 hours it is recommended to change engine and gear oil and to tighten up the cylinder head and to check or to possibly adjust the tension of the V-belt. Besides, it is recommended to let an authorized service dealer go over engine and installation.

MAINTENANCE

Belt for alternator

To be adjusted every 150 hours by turning the alternator round the centres of suspension. Tensioning should be so as to allow 8 - 10 mm deflection of the belt under firm thumb pressure.

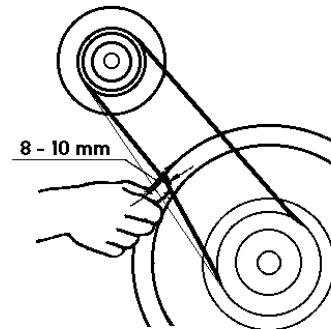

Air inlet filter

This is a wire gauze filter to be rinsed in petrol and cleaned by a blast of compressed air after 300 hours' operating.

Fuel filter

A fuel filter is fitted between the fuel lift pump and the H.P. fuel pump. The filter is a disposable one which cannot be cleaned. It should be changed every 300 operating hours or if water contamination is suspected.

Change the filter as follows:

1. Drain off the fuel from the filter by slackening drain screw A in the bottom of the filter casing B.
2. Remove by hand or by means of a pair of tongs the filter casing and discard it.
3. Clean the sealing surface of the filter holder C if necessary.
4. Fill the new filter casing with clean fuel through the holes at the top of same.
5. Screw on the filter casing and tighten it by hand about half a turn after the gasket fits tightly.
6. After changing the filter, bleed the fuel system as stated under "Preparation for first start"

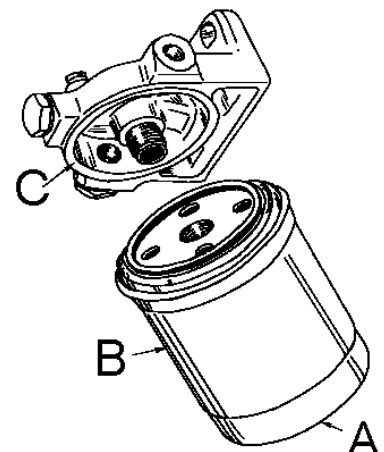

Fuel lift pump

The fuel lift pump is a cam shaft driven sealed type diaphragm pump, which cannot be dismantled for repair or cleaning. It is recommended to install a water/dirt accumulating filter in the suction line to the pump.

After repairs the fuel system must be bled as described under "Preparation for the first start" if necessary.

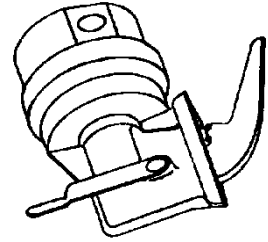

Lubricating Oil System

The engine is pressure lubricated and the oil system has a built-in relief valve for controlling the oil pressure. A lubricating oil cooler is also fitted. The oil level is checked as mentioned before.

Change of Oil

Lubricating oil should be changed for the first time after 25 hours of running, later for every 150 hours or at least once a year. It is recommended to change the oil when engine is warm, and the procedure is as follows:

1. Turn the left cock below oil bilge pump 90°.
2. Pump up the oil from the sump by means of the bilge pump.
3. When the sump is empty pour fresh oil.
4. Check oil level on dipstick.

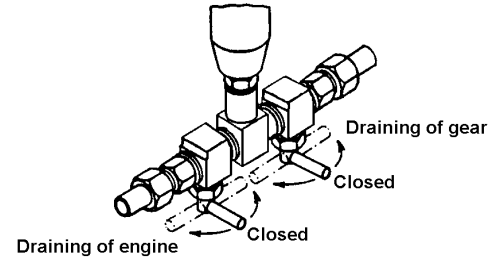

Recommended Lubricating Oil

Modern diesel engines demand heavy-duty oils with additives securing best operation conditions and longest life time of the engine under various conditions.

Therefore use a first class HD-oil from a recognized oil company.

Oil specifications as mentioned in "LUBRICATION OIL CHART".

When operating under difficult conditions, i.e. frequent cold starting, short operation periods, greatly varying loads, use quality "Service CD" and also use quality "Service CD" in case the sulphur content of fuel is higher than 1 %.

Change of Lubricating Oil Filter

Lubricating oil filter cannot be cleaned, but should be changed every 150 hours or once a year. To change the filter proceed as follows :

1. Unscrew filter A and discard it.
2. Clean the sealing surface of the engine B, and remove old gasket C if any from old filter
3. Mount new filter at once under clean conditions.
4. Screw on filter until gasket fits tightly, tighten a further half turn.
5. Fill with oil until normal level is reached.
6. Start the engine and check that the filter is tight.

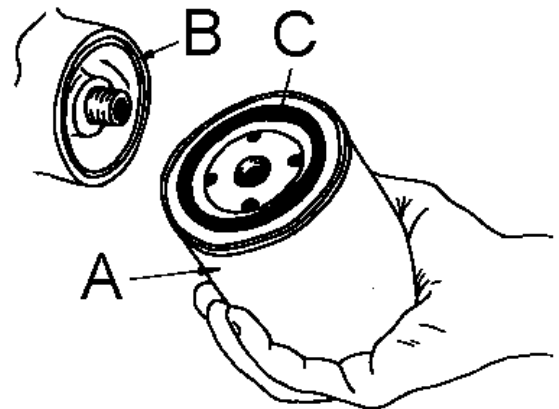

Cooling water system

Normally the engine is direct seawater-cooled, however, alternatively it can be delivered with freshwater-cooling, or it may be fitted with this later on. Freshwater-cooling is particularly used in boats running more than 500 hours a year.

Seawater cooling

From external strainer the cooling water is drawn through the lubricating oil cooler to the pump from where the water is fed through the cooling jackets up to the cylinder head and from there, via the watercooled exhaust manifold and thermostat overboard, through the exhaust pipe. A thermostat is fitted in the watercooled exhaust manifold. This ensures a constant cooling-water temperature between 50-75°C

Exchange of zinc anode

In order to protect against corrosion in the engine cooling-water system, there is one zinc anode fitted on the starboard side of the crankcase under the water-cooled exhaust manifold. The zinc anode must be checked 2-3 times during the season, dependent on the waters you are sailing in. If the zinc anode is corroded away it must be replaced.

Exchange of impeller in cooling-water pump

The cooling-water pump is a rotary pump with a neoprene impeller. The impeller cannot stand up to dry running for more than 20 sec., and this is why you must make sure before starting the engine that the sea-cock is open. When building the boat or during winter storage of the engine, you must not put water pressure to the seawater in-take, as this may fill the engine cylinders with water. Due to varying temperatures and the one-sided deformation during the winter storage, the impeller should be taken out and kept separately during this period. Change the impeller by slackening the six screws in the cover of the pump, remove the cover and withdraw the impeller which is fitted on a multi spline shaft. Too high cooling temperature (defective pump impeller) or defects on thermostat will cause the blue lamp in the control panel to light up and the acoustic alarm to function. If the thermostat is removed, the by-pass for cooling water has to be closed.

OPERATING MANUAL FOR BUKH DV36ME ENGINES

Freshwater cooling

When using freshwater cooling it will be possible to reach a higher operating temperature of 70-95°C which will prolong the life of the engine. This cooling system is recommended for engines operating for more than 500 hours a year.

A pump circulates the freshwater in a closed system.

This circulation pump is fitted on the back end of the engine. The fresh water circulates through the cooling jackets of the engine and through the heat exchanger fitted on the water-cooled exhaust manifold. The freshwater is cooled in the heat exchanger by seawater which is pumped through by a big impeller pump like the one used for direct seawater-cooling.

The seawater leaves the heat exchanger via the exhaust system as in the case of seawater cooling.

Frost precautions

To avoid damaging the engine, drain the cooling water during frosty periods.

To protect the engine against damage caused by frost, proceed as follows:

1. Turn off the cock on the cooling water inlet skin fitting.
2. Drain the cooling water off the engine by removing the plug above the lubricating oil filter on starboard side and under the exhaust manifold, respectively.
3. Clean up the drain holes with a nail, a steel wire or the like, so that any remaining water may drain out.
4. Start the engine and let it run for 30 seconds to remove all the water from engine and exhaust manifold. Running for that short time will cause no damage to the impeller of the pump.

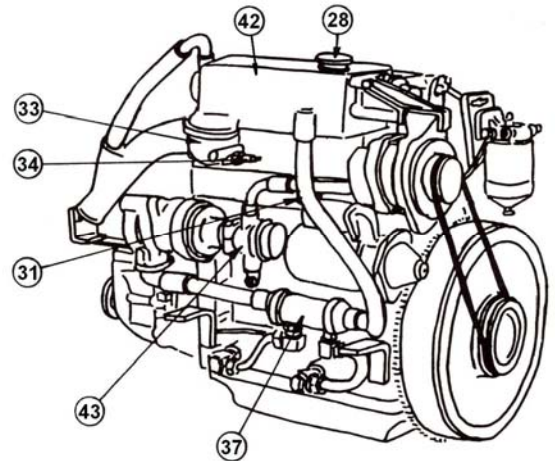

- 28. Cooling water filling plug
- 31. Zinc anode
- 33. Thermostat housing
- 34. Temperature transmitter
- 37. Lubricating oil cooler
- 42. Heat exchanger
- 43. Cooling water pump

On engines fitted with heat exchanger cooling it is recommended to use a mixture of **min. 30% antifreeze liquid and 70% water** and **max. 50% antifreeze and 50% water** as protection against corrosion and to secure the cooling water freezing temperature to min. minus 15° Celsius or lower if required from climate conditions.

However **please also note when doing service on the boat** that the mix of water and antifreeze can get aggressive and start corrosion. If corrosion is found in the cooling system it can be caused by one of two conditions:

1. The anti corrosion additives in the anti freezing liquid are exhausted and have evaporated.
2. Oxidation due to incoming air causing an acid which is lowering the PH value.

Therefore and also to keep the anti freezing properties it is recommended to **change the cooling water and antifreeze every 3 years min.** Please also note the details provided by your supplier of antifreeze liquid normally stated on the can.

Heat exchanger freshwater capacity for DV36 is approx. 7.0 litres.

Drain the raw water from the heat exchanger cooled engines by taking off the seawater pump cover.

Electrical System

The engine is equipped with a 12 volt electrical system consisting of a starter motor and an alternator, the max. charging current of which is 50 Amp.

Electrical wiring diagram for the engine with control and instrument panels is shown later in this instruction.

The level of the electrolyte in the battery should be checked every 14 days or every 25 operating hours. The level should be 5-6 mm above the plates, if this is not the case top up as required with distilled or demineralized water.

The battery must never be isolated from the alternator, when the engine is running.

Warning! It is not allowed to connect additional equipment to the wiring system on the engine. Possible additional equipment has to be connected directly to the terminals of the battery.

NOTE!

The starter must not be operated for more than 10 sec. If further operation is necessary, a pause of at least half a minute before starting attempt is repeated.

Marine Gear

The engine is equipped with a reverse-reduction gear. The standard reduction is 3:1 for AHEAD and 2.5:1 for REVERSE (but also available as 2.5:1 for special purposes).

The marine gear will need no other attendance than regular change of oil. This to be carried out after 25 hours of operation, and then every 150 hours or once a year.

See oil quality under "Technical data" .

The oil change is carried out by means of the lubricating oil bilge pump fitted on the engine.

The oil should be warm when draining.

Refill new oil to the quantity of 0.8 liters through the dipstick hole.

Check oil level on the dipstick.

Don't forget to close the cock before starting up.

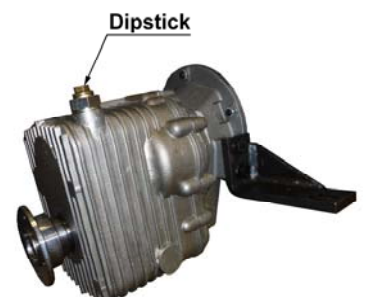

Propeller equipment (As supplied by BUKH – for other types consult individual manufacturer’s instructions)

Flexible stern tube: Every three years replace the three seal rings in the stuffing box “A” and the rubber hose “B” connecting stuffing box and intermediate tube “C”. Fill the flexible stuffing box “A” with Out-board gear oil through the filler hole in this or via the automatic stern tube lubrication “D” supplied as extra equipment to the stern tube arrangement.

Normally the consumption of Out-board gear oil is not considerable, and therefore, a sudden increase indicates defective sealing rings.

The container “D” should be mounted about 0.25 m above the water line.

Example of stern tube arrangement

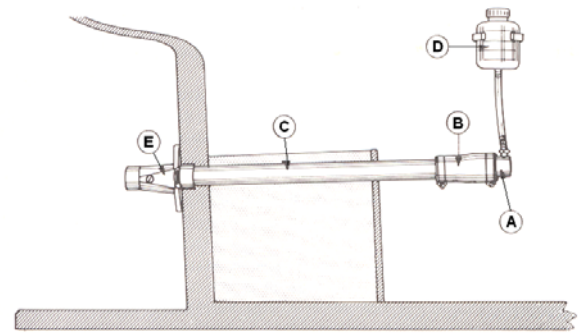

- A. Stuffing box with seal rings
- B. Flexible tube between stuffing box and stern tube
- C. Stern tube
- D. Filler tank for automatic stern tube lubrication
- E. Rear stern tube bearing (water lubricated rubber bearing)

Sail drive

As an alternative to the marine gear, the engine can be equipped with a sail drive. The sail drive has the same function as the reverse-reduction gear.

The reduction is **2.25:1** for AHEAD and for REVERSE. The sail drive will need no other attention than regular change of oil. Change of oil should be carried out after the first 25 hours of operation, then every 150 hours or once a year.

Carry out the oil change when the boat is on land by loosening the screw “D” in the bottom of the drive, enabling the oil to run out.

Refill the fresh oil to a quantity of 3.3 ltr. through the filter hole “B” at the top of the drive corresponding to the upper mark on the dipstick “A”.

Use the same quality of oil as indicated under “Technical Data” for the marine gear.

A replaceable zinc anode “C” is fitted on the sail drive. Check this anode once a year, replace it in case of considerable corrosion.

Only use a propeller which is insulated from the shaft and the leg!

Check that there is good electrical connection between the zinc anode and the bearing hub through the two mounting screws.

The sail drive is equipped with a double diaphragm “F” preventing penetration of seawater. In the double diaphragm a sensor “E” is fitted which releases an acoustic alarm if water penetrates between the two diaphragms. It is important for the sake of safety that this alarm is always serviceable. It should be checked twice a year by short-circuiting the connections 1 and 2 on the plastic box next to the multiple plugs.

When short-circuiting here by means of a piece of wire or a screw-driver, the buzzer should give alarm.

The aluminium housing of the sail drive has been specially treated on the outside. Damage to surface treatment should be treated as soon as possible with special BUKH paint. The sail drive should be coated with the same paint as the rest of bottom of the boat.

This paint must not contain copper.

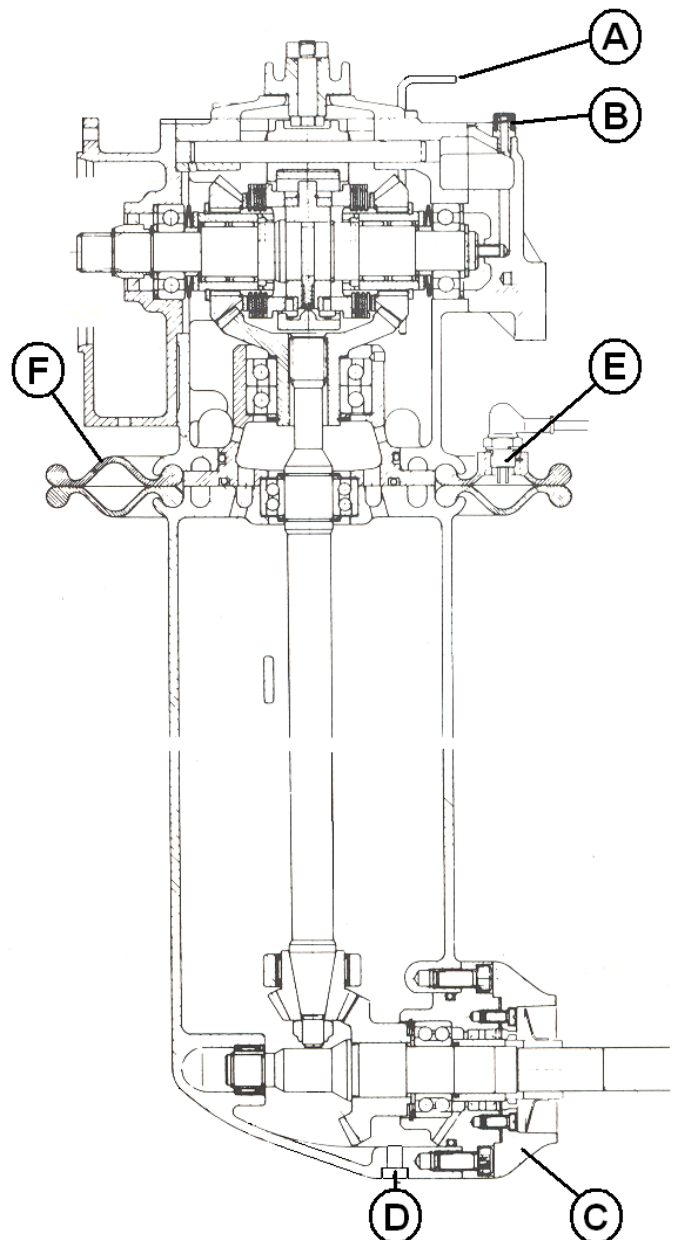

Galvanic corrosion

To avoid corrosion of the propeller due to galvanic action it is advisable to fit a sacrificial zinc anode on the outside of the hull. To obtain a high degree of protection, electrical contact between sacrificial zinc (anode) and propeller (cathode) has to be established. This is obtained by fitting the sacrificial zinc and connecting electrically, as shown on the sketch.

For the DV36 a sacrificial zinc of BERA 2B type is recommended.

The sacrificial zinc must not be painted or be otherwise insulated, as this will prevent the zinc from corroding.

The sacrificial zinc must be checked everytime the boat is ashore, or at least twice a year.

If the corrosion turns out to be very heavy, bigger anodes, e.g. 2 pcs. BERA 2B or 1 pc. BERA 1, should be fitted. If there is no corrosion, check the electrical connections. A good way of fitting the sacrificial zinc is to fold down one of its flaps and to clamp it to the stern bearing by means of a rustproof clip as shown on the sketch.

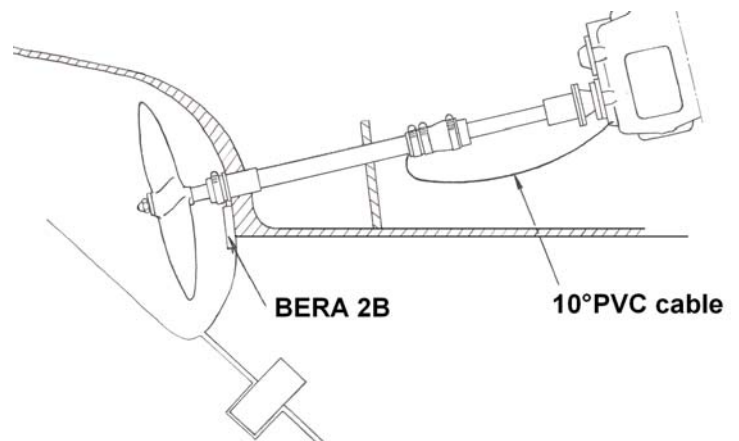

Starting instructions for BUKH Diesel Engine type DV36ME

Electric start:

1. Switch on the main switch.
2. Put the gear into neutral position
3. Turn the start switch to the right until the engine starts

Hand start (Emergency start):

- a. Put the gear into neutral position
- b. Put the handle into the crank claw
- c. Lift the decompression lever (1)

Only for cold start (below 0°C, if mounted):

Start pilot: Pull and push the pump (2) 2-3 times.

- d. Turn the starting handle counter-clockwise as quickly as possible, release the decompression lever but keep on turning until the engine starts.

Stopping the engine:

Turn the start switch to the left.

After the engine has stopped:

Turn the switch right to neutral position.

Filling the pressure tank (3) (if mounted):

1. Open the cover.
2. Put the gas cylinder on top of the valve and fill up the tank to max. marking.

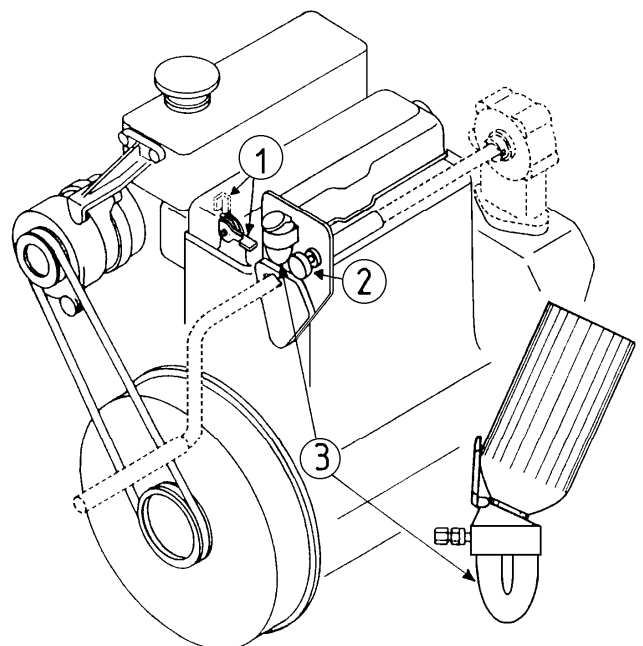

WINTER STORAGE OF THE ENGINE

1. Carry out the following whilst the boat is still in the water:

1. Run the engine until normal working temperature is reached.
2. Drain off engine and gear oil with the oil bilge pump.
3. Fill the engine and gearbox with preservative lubricating oil of a recognized make up to the upper mark on the dipstick.
4. Fill the fuel tank with fuel preservative oil in the rate of mixture prescribed by the oil manufacturer.
5. Start the engine and let it run for about 10 minutes to be sure that the fuel mixed with preservative oil has been flushed through the fuel system of the engine.
6. Fill the fuel tank completely with fuel. Pay no special attention to the preservative oil previously added to the fuel as this is consumed normally and properly when service is resumed in spring.

2. On land the following procedure has to be carried out:

1. Remove the engine cooling water drain plugs, drain off the sea water from the engine and refit plugs.
2. For direct sea water cooled engines: Remove the suction hose from the cooling water pump at the bottom cock and put the hose into a bucket with freshwater containing preservative oil in the rate of mixture prescribed by the oil manufacturer
3. The outlet hose for the cooling water which goes into the exhaust elbow may be removed and returned to the bucket via a length of hose so that the freshwater is able to circulate. Start the engine and the freshwater containing preservative oil will be flushed through the engine.
4. Stop the engine after 5 - 10 minutes and drain off the water. Ensure that after removing the drain plug (1 plug is placed in the block, see fig. 4, pos. 24; and 1 plug in the exhaust manifold) all the water is drained off. This is done by cleaning the drain holes with a nail, a steel wire or the like, so that any remaining water may drain out. Remove the impeller from the cooling water pump, which will allow water in pump and pipes to be drained off. Keep the impeller separately in a dry place during the winter.
5. A: For freshwater-cooled engines:
6. Drain the freshwater from the engine by removing the plugs as indicated for seawater cooled engines. It is not necessary to flush this system with freshwater containing preservative oil. If the engine is to be used in period of frost, it must be protected against frost burst with a mixture of anti-freeze solution in the freshwater system - irrespective of the protection to the freshwater system against the risk of frost - by removing the cover of the impeller pump and turning the engine manually or with the starter motor.
7. Remove the battery and store it separately during the winter in a dry and frost-free place. Fill up and charge the battery before storing.
8. Remove the air filter and turn the engine manually until each inlet valve opens alternately, during which about 1/2 cup of preservative oil is injected into each piston head. Turn the engine backwards and forwards manually in order to spread the preservative oil.
9. Insert a clean, oil moistened rag (not cotton waste) into the inlet manifold.
10. Insert another clean, oil moistened rag into the exhaust elbow aperture.
11. Treat electrical connections with grease free from acid. Fill the multiple plugs with grease from the wire side.

The engine is now preserved for winter storage and can be further protected by covering of polythene sheeting, under which a bucket of silicagel should be placed.

3. Preparation of engine before launching.

1. Remove the oil moistened rags from the inlet manifold and the aperture of the exhaust elbow.
2. Fit the cooling water pump impeller.
3. Fit cooling water drain plugs.
4. Drain the preservative lubricating oil from both engine and gearbox and fill up with fresh oil to the upper mark of the dipstick.
5. Change the lubricating oil filter.
6. Make sure - before starting up - that the oil on the piston heads is drained off. This is checked by turning the engine manually without operating the decompression lever.
7. Examine the stern tube stuffing box and fill up with stern tube oil.
8. Fit the battery after re-charging.
9. Lubricate all moveable parts with oil.
10. Check the anode.
11. Check that there is electrical contact at the stern tube at the internal connection to the gearbox.

TECHNICAL MAIN DATA	DV36ME
WORKING PRINCIPLE.....	4-STROKE
NUMBER OF CYLINDERS.....	3
CYLINDER BORE/STROKE.....	85 mm / 85 mm
CYLINDER VOLUME.....	1.447 Litres
COMPRESSION RATIO.....	18,5:1
COMPRESSION PRESSURE at 3600 rpm.....	47 Bar
OUTPUT, CONTINOUS RATING at 2400 rpm.....	29.8 BHP - 21.9 kW
ACCORDING TO ISO 3046 at 3000 rpm.....	34.5 BHP – 25.4 kW
..... at 3600 rpm.....	36.0 BHP - 26.5 kW
OUTPUT, INTERMITENT RATING BHP... at 4000 rpm.....	39.3 BHP – 28.9 kW
MAX. TORQUE Kp*m..... at 1800 rpm.....	9.2 Kpm – 90 Nm
MAX. AIR CONSUMPTION.....	2214 Litres/min.
ENGINE ROTATING, LOOKING AT FLYWHEEL.....	CLOCKWISE
IDLING SPEED.....	800 – 1000 RPM
MAX INCLINATION, FORE AND AFT.....	15°
HEEL, MAX. CONTINOUS.....	30°
NET WEIGHT INCL. ZF MARINEGEAR.....	265 Kg
LOCATION OF ENGINE SERIAL NUMBER.....	CRANKCASE NEAR FUEL PUMP
EXHAUST TEMP. MAX / NORMAL.....	600°C – 580°C
VALVE TIMING AND INJECTION POINT	
FLYWHEEL DIAMETER.....	370 mm
INLET VALVE OPENS..... BEFORE TDC.....	32° (arc measure: 103 mm)
INLET VALVE CLOSES..... AFTER BDC.....	64° (arc measure: 207 mm)
EXHAUST VALVE OPENS..... BEFORE BDC.....	64° (arc measure: 207 mm)
EXHAUST VALVE CLOSES..... AFTER TDC.....	32° (arc measure: 103 mm)
INJECTION STARTS..... BEFORE TDC.....	6.2° (arc measure: 20 mm)
VALVE CLEARANCES (COLD ENGINE) INLET/EXHAUST.....	0.30 mm
FUEL SYSTEM	
INJECTOR OPENING PRESSURE.....	DIRECT INJECTION
INJECTION TIMING.....	210 Bar
FUEL LIFT PUMP.....	AUTOMATIC VARIABLE
STATIC PRESSURE OF FUEL LIFT PUMP.....	CAM SHAFT DRIVEN DIAPHRAGM PUMP
FUEL FILTER.....	153 - 285 mBar
FUEL QUALITY GAS OIL.....	THROW AWAY FILTER INSERT
	BS 2869 CLASS A
LUBRICATING SYSTEM	
TYPE OF LUBRICATING OIL PUMP.....	ROTARY VANE PUMP
LUBRICATING OIL PRESSURE: WARM ENGINE / MINIMUM.....	2-4.5 Bar / 1 Bar
LUBRICATING OIL QUALITY.....	SERVICE CC or CD
LUBRICATING OIL VISCOSITY..... BELOW +5°C.....	SAE 10 or SAE 10W-30
..... BETWEEN +5°C and +25°C.....	SAE 20 or SAE 15W-40
..... ABOVE +25°C.....	SAE 30 or SAE 15W-40
LUBRICATING OIL CONTENT INCL. FILTER.....	4.9 Litres
LUBRICATING OIL FILTER.....	THROW AWAY FILTER INSERT
PRM 120 MARINEGEAR	
LUBRICATING OIL QUALITY.....	Automatic Transmission Fluid (ATF)
LUBRICATING OIL TEMPERATURE.....	MAX. 120°C
LUBRICATING OIL CONTENT.....	0.8 Litres
STERN TUBE (FLEXIBLE) LUBRICANT.....	OUTBOARD GEAR OIL
COOLING WATER SYSTEM (Direct cooling)	
COOLING WATER TEMPERATURE.....	50 – 70°C
TYPE OF CIRCULATING PUMP / CAPACITY AT 3600 rpm.....	CENTRIFUGAL / 24-30 Litres/min
COOLING WATER SYSTEM (Indirect cooling)	
COOLING WATER TEMPERATURE.....	70 – 95°C
TYPE OF SEAWATER PUMP / CAPACITY AT 3600 rpm.....	CENTRIFUGAL / 36-42 Litres/min
TYPE OF FRESHWATER PUMP / CAPACITY AT 3600 rpm.....	CENTRIFUGAL / 135 Litres/min
COOLING WATER CONTENT.....	7.0 Litres
ELECTRICAL SYSTEM	
BATTERY VOLTAGE / CAPACITY.....	12 VOLT / 88 Ah
STARTER TYPE / OUTPUT.....	GEAR DRIVEN / 1.2 KW
ALTERNATOR TYPE/ OUTPUT.....	BELT DRIVEN / 700 W
ENGINE STOP.....	SOLOINOID / MANUAL
RELAY.....	ELECTRONIC, BUILT ON
TORQUES	
CYLINDER HEAD BOLTS/BEARING TOP SECTION.....	118 +/- 5 Nm (12 +/- 0.5 Kpm)
CONNECTING ROD BOLTS.....	69 +/- 3 Nm (7 +/- 0.3 Kpm)
FLYWHEEL/COUNTERWEIGHTS.....	147 +/- 7 Nm (15 +/- 0.7 Kpm)
FLEX. COUPLING.....	61 +/- 3 Nm (6.3 +/- 0.3 Kpm)
ASSEMBLY OF FUEL VALVE.....	59 +/- 3 Nm (6.0 +/- 0.3 Kpm)
BRACKET FOR ENGINE SUPPORTS.....	69 +/- 3 Nm (7 +/- 0.3 Kpm)
ZF- GEARBOX.....	25 +/- 5 Nm (2.5 +/- 0.5 Kpm)

RECOMMENDED MAINTENANCE AND A CHECK LIST FOR BUKH ENGINES

	CHECK	RECTIFY IF NEEDED	W E E K L Y	M O N T H L Y	Y E A R L Y	EVERY 5 YEARS
1. Tightness of connections through hull:						
1.1 stern tube	hull connection	change sealing			X	
2. Check of lubricating oil:						
2.1 a engine	change oil	-			X	X
2.1.b engine	check oil level	-	X			
2.2.a gearbox	change oil	-			X	
2.2.b gearbox	check oil level	-	X			
2.3 lubricating oil filter	change	-			X	
3. Check of cooling watersystem:						
3.1 system	system to be full	fill up	X			
3.2 anti freeze liquid	check for minus 25°C.	refill anti freeze liquid			X	
3.3 cooling water connections tightness	for leaks	renew if leaking		X		
3.4 condition of rubber hoses	cracks and leaks	renew				X
3.5 V-belt for cooling water pump	adjust or renew	-		X		
3.6 thermostat	renew after 5 years	-				X
4. Check of fuel system:						
4.1 supply line	clean water/fuel separa-tor and check line bends	repair if damaged or renew				X
4.2 fuel tank	drain for water	-			X	
4.3 fuel filter	change	-			X	
4.4 return line	check for bends & damages	repair if damaged or renew				X
5. Check of remote control cables:						
5.1 cables	check easy operation and stroke sufficient	adjust cables				X
6. Check of propeller shaft arrangement:						
6.1 rear stern tube bearing	check clearance for bearing insert	renew insert				X
6.2 sufficient water flow to rear stern tube bearing	check that water holes in bearing housing are not blocked	clean holes				X
6.3 alignment of gear flange and prop.shaft flange	alignment to be within 0.05-0.01mm	realign the engine				X
6.4 stuffing box seals	tightness	renew all three seals				X
6.5 condition of rubber tube for stuffing box	cracks	renew				X
6.6 Out-Board gearoil.	oillevel	refill		X		
6.7 propeller	check size and condition	renew if damaged				X
7. Starting of the engine:						
7.1 start with electrical start	engine start within 2 minutes	if malfunctions -the engine must be serviced by a mechanic	X			
7.2 start with handstart	same	same		X		
8. Engine maintenance						
8.1 valve clearance	clearance	adjust			X	
8.2 electric starter	rust protection of starter drive	spray rust protection spray			X	
9. Running with engine - check:						
9.1 Idling speed to be 900-1200 RPM	900-1200 RPM	adjust RPM	X			
9.2 Full speed unload /min. 3700 RPM	min. 3700 RPM	adjust RPM	X			
9.3 Full speed loaded with propeller	3300-3600 RPM	adjust RPM			X	
9.4 Cooling water temp. to be max. 75 degr. Celcius	max. 75°C	change thermostat		X		
9.5 Audible and visual alarms	check function	change senders, lamps or switch			X	
9.6 Lubricating oil pressure	min. 1.5 kg/cm ² at idling	adjust oil relief valve				X
9.7 Gearbox change from FW to Neutral to ASTERN	check cables	adjust	X			
10. Air supply:						
10.1 air inlet filter	renew	-				X
11. Bateries:						
11.1 level of liquid	check, refill	renew	X	X	X	X
11.2 voltage conditon	charge	renew		X		

IRREGULAR OPERATION - CAUSES AND REMEDIES

1. Engine does not start

SYMPTOM	CAUSE	REMEDY
Insufficient or very little compression	Inlet and/or exhaust valves leaking	Grind or replace the valves, mill the seats
	Inlet and/or exhaust valves sticking	Grease valve stems with 2/3 gas oil and 1/3 lub. Oil. If necessary clean the valves.
	Insufficient rocker arm clearance	Adjust to 0.25 mm inlet and 0.3 mm exhaust when engine is cold (turn left)
	Piston rings stuck in grooves or are worn	Replace piston rings
	Valve springs broken or are weak	Replace springs
Insufficient or no pressure from fuel pump	Air in fuel system or nozzles sticking	Bleed or renew nozzles
	Thermo start out of order	Fill up (renew thermo-start)
Engine does not reach normal revs	Electric supply out of order	Check and/or replace switch and connections. Check fuse
	Unloaded battery or defective	Battery to be charged or renewed
Starter motor turns engine too slowly	Loose or corroded connections	Tighten or clean connections

2. The engine starts, but stops soon after

The engine starts, but stops soon after	Empty fuel tank	Refill and bleed
	Air in fuel system	Bleed
	Nozzle sticking	Replace nozzle
	Fuel filter choked	Replace filter element. Clean the tank

3. The engine does not reach maximum output

Difficult to start	None or insufficient compression	See "engine does not start"
The engine revs. Is reduced considerably when loaded	Fuel supply choked up.	Check fuel system thoroughly
	Air/water in fuel system	
	Governor incorrectly adjusted or something in the system works sluggishly	Adjust the governor. Check governor system and correct the error
Hot engine(smell of heat)	Insufficient cooling water supply	Stop engine. Check cooling water pump
	Damaged cylinder liner or bearings	Check bearings, piston and cylinder, if necessary replace them

4. The engine knocks

The engine runs unevenly	Air/water in fuel system	Bleed see "engine does not start"
--------------------------	--------------------------	-----------------------------------

5. The engine smokes

Black smoke	Air inlet filter choked	Clean filter
	Insufficient compression	See "engine does not start"
Blue smoke	The lube oil passes piston and oil rings and penetrates into combustion chamber, or vacuum valve defective	Replace oil rings and possibly the piston rings. Clean vacuum valve
Grey smoke	Thermostart valve is leaking	Replace

6. Excessive consumption of lubricating oil

Blue smoke	Oil- and piston rings are worn	Replace oil- and piston rings, if required
	Piston and cylinder liner highly worn	Replace
	Defective vacuum valve	Replace
Lub. oil leaks out of crankshaft bearings	Worn oil seal ring	Replace

7. The engine gets too warm or too cold

Cooling water temperature too high (smell of heat)	Insufficient cooling water supply caused by: defective water pump, choked strainer or a defective thermostat	Investigate pump rotor for broken wings or lost driver screw. Clean strainer. Clean or replace thermostat
Cooling water temperature too low	Defective thermostat	Clean or replace thermostat

8. Insufficient or no lubrication oil pressure

Oil warning lamp lights up. Oil pressure gauge indicates abnormally low oil pressure	Insufficient lube oil in the engine	Check and refill
	Leakage in lube oil system	Tighten and refill
	Relief valve sticking or spring too weak	Clean bore and valve, stretch or replace the spring

LUBRICATING OIL CHART

OIL COMPANY	OIL TYPE	HD OIL GRADE & QUALITY	Lubricating oil for engine: temp range				Auxiliaries	
			Below -15°C	Below 5°C	5°C - 25°C	Above 25°C	PRM120 gear (ATF)	Stern tube (flexible)
BP OIL	VISCO 5000	SAE 5W-40 API SJ/CF	X					
BP OIL	Vanellus C4 Global	SAE 15W-40 API CF-4/CF/SG		X	X	X		
BP OIL	Vanellus C3 Extra	API CF4/CE/SF		X	X	X		
BP OIL	Outboard Gear Oil Universal							X
BP OIL	Energol GR-XP 150	DIN 51 517 del. 3						X
BP OIL	Energol GR-XP 220	DIN 51 517 del. 3						X
CALTEX	Havoline Fully Synthetic	SAE 5W-40 API SJ/CE	X					
CALTEX	Delo 350 Multigrade	SAE 15W-40 API CF4/CJ		X	X	X		
CALTEX	Outboard Gear Oil EP	SAE 90						X
CASTROL OIL	CASTROL Syntruck	SAE 5W-40 API CF	X					
CASTROL OIL	CASTROL RX Super Plus	SAE 15W-40 API CH-4		X	X	X		
CASTROL OIL	CASTROL Marine Gear Oil	SAE 90						X
CHEVRON	DELO 400 Synthetic	SAE 10W-30 API CD/SG + SF	X					
CHEVRON	RPM HEAVY DUTY	SAE 15W-40 API CD - II		X	X	X		
CHEVRON	GEAR COMPOUND EP 220	ISO VG 220						X
ELF	Elf Synthèse 5W/40	SAE 5W-40 CD or CC	X					
ELF	Performance 3D 15W-40	SAE 15W-40 CD or CC				X		
ELF	Performance 3D 10W-30	SAE 10W-30 CD or CC		X	X			
ELF	Outboard Gear Oil	SAE 85W-90						X
EXXON / ESSO	EXXMAR CM	SAE 15W-40	X	X	X	X		
EXXON / ESSO	ESSOLUBE XT301	SAE 15W-40 API CG-4	X	X	X	X		
EXXON / ESSO	ESSOLUBE XT301	SAE 15W-40 API CG-4 FZG11						
EXXON / ESSO	SPARTAN EP220	ISO VG 220						X
EXXON / ESSO	GEAR OIL GX	SAE 80W-90						X
MOBIL OIL	MOBIL 1 0W-40	SAE 0W-40 API SJ/CF/EC	X	X	X	X		
MOBIL OIL	MOBIL Delvac 1 SHC	SAE 5W-40 API CE/CD	X	X	X	X		
MOBIL OIL	MOBILGARD 1 SHC	API CD/CF/CF2	X	X	X	X		
MOBIL OIL	MOBILGARD HSD	15W-40 API CG-4/CF-4/CF/SH		X	X	X		
MOBIL OIL	MOBIL Stern Tube Lubricant	Outboard Gear Oil SAE 80-90						X
NIPPON OIL COMPANY	HIDIESEL S-3 SAVE	SAE 15W-40 CD	X	X	X	X		
NIPPON OIL COMPANY	HIDIESEL S-3 SAVE	SAE 10W-30 CD		X	X	X		
NIPPON OIL COMPANY	GEAR LUBE EHD	SAE 90						X
SHELL OIL	Helix Ultra	SAE 5W-40	X					
SHELL OIL	Rimula X	SAE 10W-30		X				
SHELL OIL	Rimula X	SAE 15W-40			X	X		
SHELL OIL	Nautilus Marine Gear Oil	SAE 90						X
SHELL OIL	Spirax GX	SAE 80W-90						X
STATOIL	LazerWay 5W-40	SAE 5W-40 API SL/CF	X					
STATOIL	PowerWay 15W-40	SAE 15W-40 API CF4/SJ		X	X	X		
STATOIL	LoadWay EP 220	ISO VG 220						X
STATOIL	GearWay G5	SAE 80W-90						X
TEXACO	Havoline Formula 3 Synthetic	SAE 5W-40 API SJ/CF	X					
TEXACO	URSA Super LA	SAE 15W-40 API CG-4		X	X	X		
TEXACO	GEARTEX EP-C	SAE 80W-90 API GL-5						X
TEXACO	MEROPA 220	ISO VG 220						X
	Dexron II or III						X	

DIRECTIONS FOR LUBRICATION

Designation	Application Point	Capacity Incl. Filter
Engine:DV36/48	Change first time after 25 h and every 150 h or once a year	4.9 Litres
PRM120 Marine Gear	Change first time after 25 h and every 150 h or once a year	0.8 Litres
Oil Filter	Change every 150 h or once a year	
Stern Tube (flexible)	Change every 3 years	

OPERATING MANUAL FOR BUKH DV36ME ENGINES

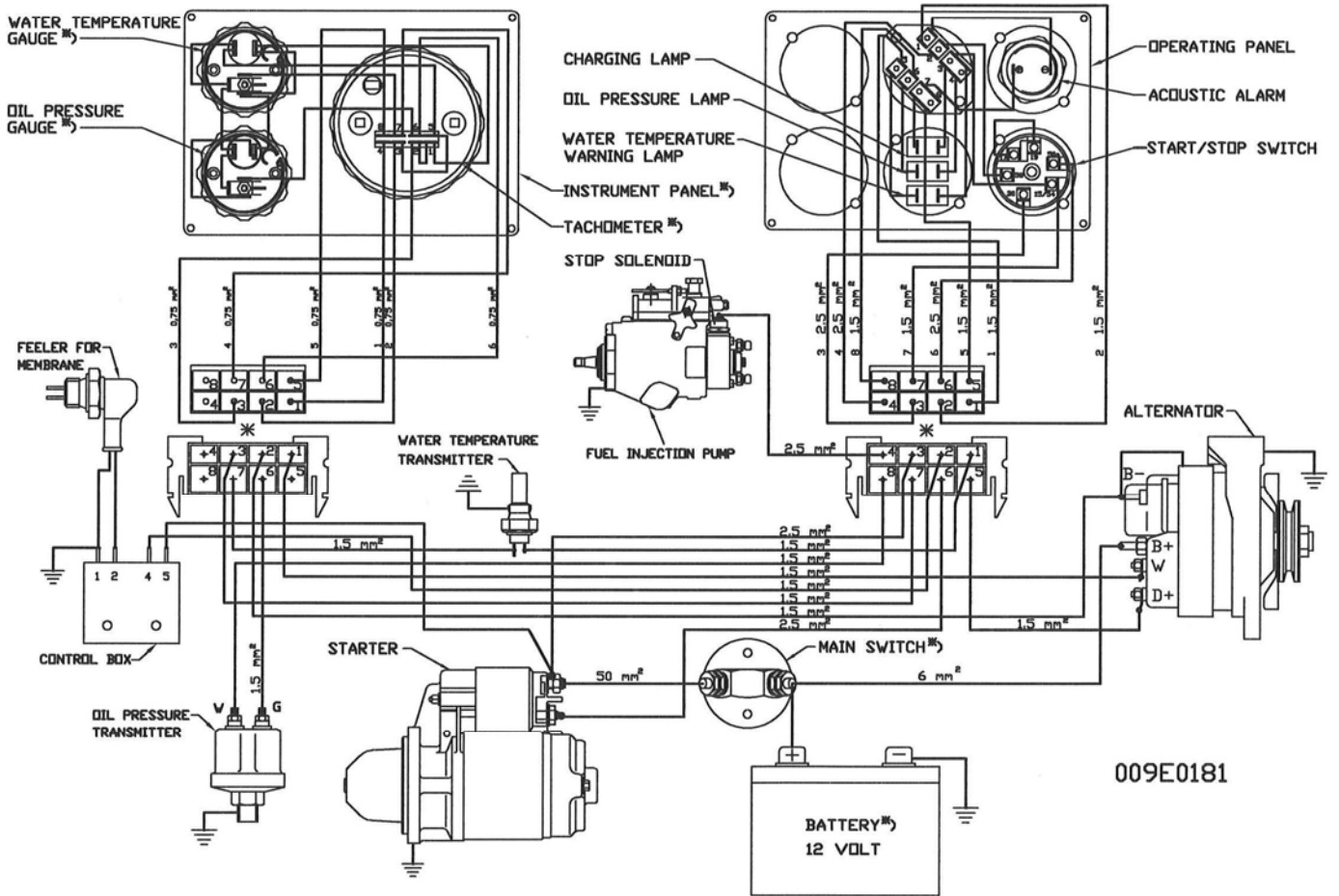
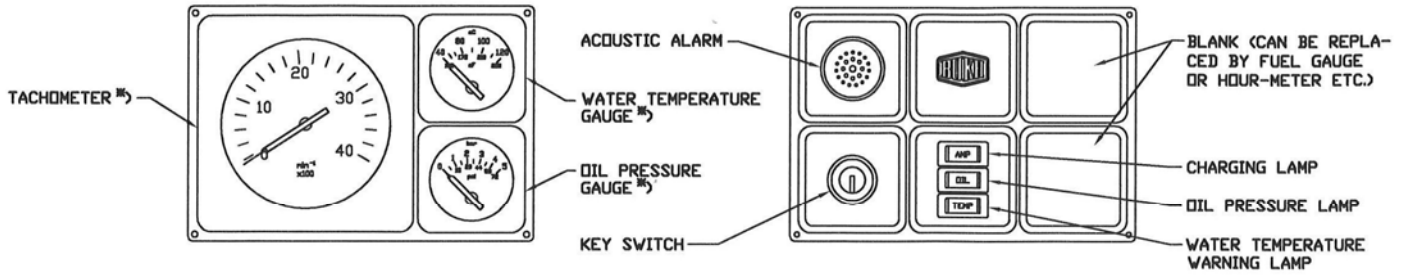

* EXTENSION CABLE CAN BE PLACED HERE

^{*)} ADDITIONAL EQUIPMENT

Key Switch Functions:

- a. Switched off (pos. before insertion and removal of key)
- b. Warning and instrument lamps are alight
- d. Start
- e. Engine stop

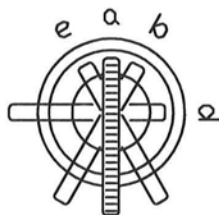

NOTE:

In order to reach positions >>d<< and >>e<< the key body must be depressed by means of the key.

The switch should not be left in pos. >>e<<, because of the heavy consumption of current by the stop solenoid. The alarm functions are tested in pos. >>e<<.

The starter must not be operated for more than 10 sec. If further operation is necessary a pause of at least half a minute must be made before starting attempt is repeated.

Pls. note page 5 and 10 "Start Instruction" for Life Boat Engines

Installation: DV36

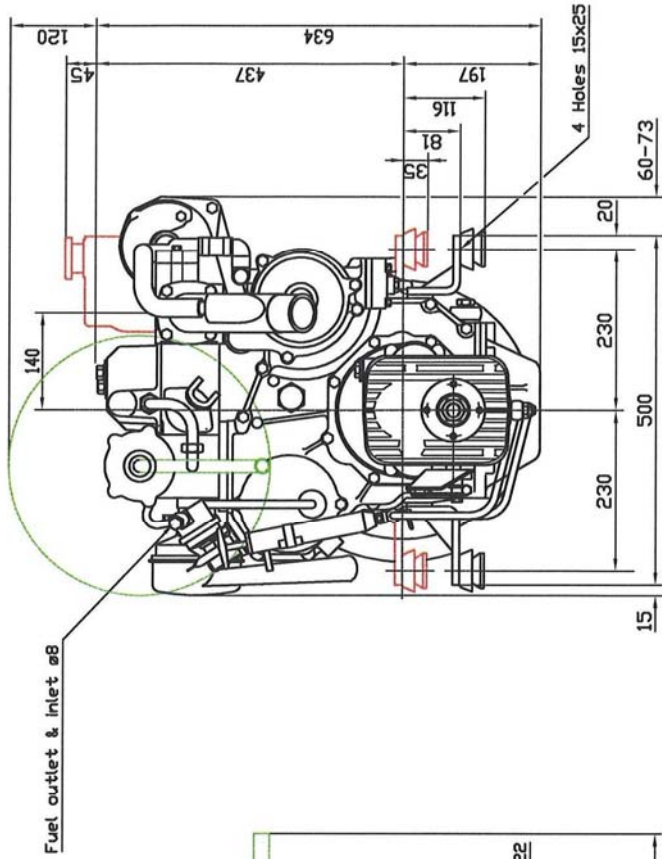

DV36ME
009M3652

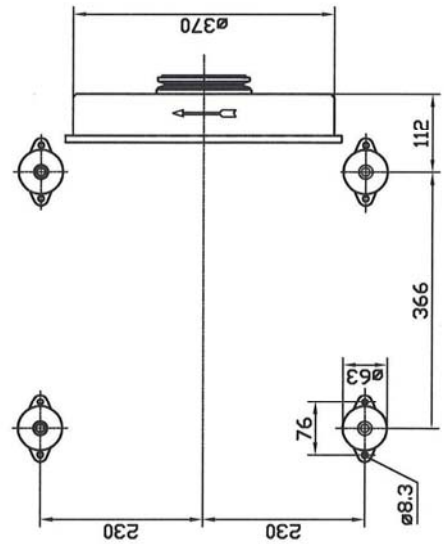
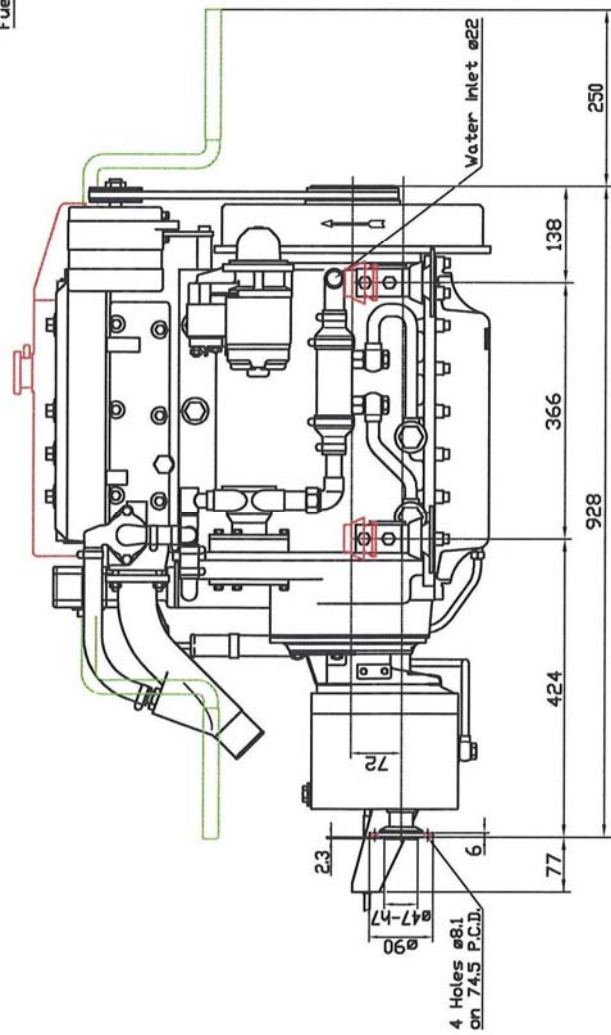

Weight incl. gear: 260 kg

BUKH DISTRIBUTORS – WORLDWIDE

Fiala & Cia. S.R.L. Av. Presidente Roque Saenz Peña 710 Piso 3º "D" 1035 Buenos Aires ARGENTINA	Tel: +54-11-4328-1474 / 6280 Fax: +54-11-4328-2838 E-mail: info@fialaycia.ar
Bukh Diesel Australia Pty. Ltd. P.O. Box 448 Caringbah, N.S.W. 1495 AUSTRALIA	Tel: +61-2-9525-0011 Fax: +61-2-9526-1084 E-mail: sales@bukhdiesel.com.au Website: www.bukhdiesel.com.au Contact: Gary Townsend
Greenland Engineers & Tractors Company Ltd (GETCO) GPO Box 541 Dhaka 100 BANGLADESH	Tel: +880-2-812164 / 812175 Fax: +880-2-813319 E-mail: getco109@citechco.net Contact: Syed Taskin Saleheen, Assistant Manager
Chimtec Ltd Baza Himsnab 9181 Razdelna Port Varna West 8211 BULGARIA	Tel: +359-8882-80563 Fax: +359-5483-0090 E-mail: dejan_tachev@yahoo.fr Contact: Dejan Tachev, Manager
Crinmar 873 Apple Down Drive Kingston, Ontario K7P 1C7 CANADA	Tel: +1-613-634-8100 Fax: +1-613-634-8110 E-mail: crinmar@crinmar.com Contact: Keith A Strutt
Chile Services Management 1001 Francia Av. Valparaíso CHILE	Tel: +56-32-210766 / 211652 Fax: +56-32-228995 E-mail: andre.quint@csenchile.cl Website: www.csmchile.cl Contact: Andre Quint, Technical Manager
Fibronaval Calle General Lagos Nº 1049 Valdivia CHILE	Tel: +56-63-210869 Fax: +56-63-208404 E-mail: fibronal@telsur.cl Contact: Jesús Brieva
Forwin Company Ltd, Qinhuangdao Office No 1-11, Nongken Building Shanhaiguan Development Zone Hebei CHINA 066206	Tel: +86-335-5082-500 Fax: +86-335-5085-036 E-mail: forwin@heinfo.net
For Win Equipment & Engineering Co Ltd Beijing Office Room 205, House Hao Bai C2 Block Building No 50 Xisanhuanbeilu Beijing CHINA 100044	Tel: +86-10-8851-5498 Fax: +86-10-8851-7458 E-mail: beijing@forwin.com.cn
Forwin Company Ltd, Shanghai Office Room 201, No 23, Lane 1299, Zhou jia zui Road Shanghai CHINA 200082	Tel: +86-21-6504-5055 Fax: +86-21-6504-49381 E-mail: forwin@uninet.com.cn E-mail: shanghai@forwin.com.cn
Forwin Company Ltd, Guangzhou Office Room 1701, Block B5, Fuli Plaza 8 Road Zhongshan, Liwan District Guangzhu, Guangdong CHINA 510140	Tel: +86-20-8135-6891 Fax: +86-20-8135-6896 E-mail: forwin88@public.guangzhou.gd.cn
Forwin Company Ltd, Tianjin Office Room 602, No 37 Xiaoyuan Xincun, Teda Tianjin CHINA 300457	Tel: +86-22-6620-1973 Fax: +86-22-6620-1509 E-mail: forwin@starinfo.net.cn
Forwin Company Ltd, Dalian Office 1-2-3, No 155, Xue Shi Street Zhon Shan District Dalian, Liaoning CHINA 116001	Tel: +86-411-2719-395 Fax: +86-411-2719-929 E-mail: forwin@public.dl.lnpta.net.cn
Forwin Company Ltd, Wuhan Office Room 2202, D. Tai Chang Flats 518 Jiefang Road, wuchang Wuhan, Hubei CHINA	Tel: +86-27-8885-1625 Fax: +86-27-8885-2147 E-mail: forwin@lol365.com
Wei Marine Shanghai Co Ltd Room 19G, No 2000 Pudong Dadao Road Shanghai 200135 CHINA	Tel: +86-21-5132-7372 / 3 / 4 / 5 / 6 / 7 Fax: +86-21-5132-7368 E-mail: infor@wei-marine.com E-mail: weiwendong@263.net.cn

OPERATING MANUAL FOR BUKH DV36ME ENGINES

<p>Montmontaza Greben d.o.o. Obala 4 Br. 50 20270 Vela Luka CROATIA</p>	<p>Tel: +385-20-812-028 Fax: +385-20-813-354 E-mail: sales@greben.hr Website: www.greben.hr</p>
<p>Imocom Ecuatoriana Cia. Ltda. Casilla 17-17-292 Quito ECUADOR</p>	<p>Tel: +593-2-447662 Fax: +593-2-447664 E-mail: imocom@uio.satnet.net Contact: Peter Bachmann</p>
<p>Dolphin Marine Co 66 Eltaweniate, Smouha Alexandria EGYPT</p>	<p>Tel: +20-3-4252179 Fax: +20-3-4252179 E-mail: info@dolphin-marine.net Contact: Hussien El Bagouri</p>
<p>Bukh Diesel (UK) Ltd. 24 Benson Road Nuffield Industrial Estate Poole, Dorset BH17 0GB ENGLAND</p>	<p>Tel: +44-1202-668840 Fax: +44-1202-660713 E-mail: bukhdiesel@diskmail.co.uk Website: www.bukh.co.uk Contact: Al Pearson, Norman Griffiths</p>
<p>Beta Group OÜ Rannamoisa tee 4 13519 Tallinn ESTONIA</p>	<p>Tel: +372-6-517-576 Fax: +372-6-517-575 E-mail: omar@paadimees.ee Contact: Omar Nelland</p>
<p>P/F Mekanik (P/F Olivar Rasmussen) Postboks 72 Fjøruevegur FO-620 Runavik FAROE ISLANDS</p>	<p>Tel: +298-447425 Fax: +298-448021 E-mail: mekanik@post.olivant.fo</p>
<p>Dan Andersson Fma. Knappelstensvägen 8 22100 Mariehamn, Åland FINLAND</p>	<p>Tel: +358-18-22514 Fax: +358-18-23515 E-mail: dan@marin-diesel.com Website: www.marin-diesel.com Contact: Dan Andersson</p>
<p>Bukh Finland Tuomisentie 16 FIN-62300 Härmä FINLAND</p>	<p>Tel: +358-10-774-5260 Fax: +358-10-774-5269 E-mail: tero.erkinhoimo@alamarinjet.com E-mail: tuula.kakkuri@alamarinjet.com Website: www.alamarinjet.com Contact: Tero Erkinheimo, Tuula Kakkuri</p>
<p>DIAM'S Les Trois Rivières 410 Avenue Janvier Passero 06210 Mandelieu FRANCE</p>	<p>Tel: +33 4 92 19 50 89 Fax: +33 4 93 47 65 11 E-mail: diams020@aol.com Contact: Raymond Allo</p>
<p>Bukh-Bremen GmbH Kornstrasse 243 28201 Bremen GERMANY</p>	<p>Tel: +49-421-535070 Fax: +49-421-556051 E-mail: info@bukh-bremen.de Website: www.bukh-bremen.de</p>
<p>Viking Hellas Ltd 34 Asklipiou Street 185 45 Piraeus GREECE</p>	<p>Tel: +30-210-413-4341 / 4459 Fax: +30-210-419-0879 E-mail: info@vikinghellas.gr</p>
<p>Clouds International B.V. Handelsweg 5 a 3411 NZ Lopik HOLLAND</p>	<p>Tel: +31-348-551644 Fax: +31-348-550873 E-mail: info@clouds.nl Website: www.clouds.nl Contact: René Verzuu</p>
<p>Marland Technical Services Ltd Room 702, Fortress Tower 250 King's Road, Northpoint HONG KONG SAR, CHINA</p>	<p>Tel: +852-2571-9322 Fax: +852-2806-3153 E-mail: lifeboat@marland.com.hk Website: www.marland.com.hk Contact: Ken Hui, Director</p>
<p>GO-ON ehf Reykjavikurvegur 68 220 Hafnarfjordur ICELAND</p>	<p>Tel: +354-566-6200 Fax: +354-566-6262 E-mail: goon@goon.is Website: www.goon.is Contact: Ármann R. Ulfarsson</p>
<p>Samarth Engineering 23, Dhumal House, 1st Carpenter Street C P Tank Mumbia 400 004 INDIA</p>	<p>Tel: +91-93-2228-8470 Fax: +91-22-2496-5574 E-mail: info@samarthgroup.com Contact: Sunil Shinde</p>
<p>Bukhindo c/o Mr Armansyah Jl. Pengadegan Barat II/6 Jakarta 12770 INDONESIA</p>	<p>Tel: +62-21-7973474 Fax: +62-21-7987294</p>

OPERATING MANUAL FOR BUKH DV36ME ENGINES

Scandiesel Via Colorado 38 28069 Trecate (NO) ITALY	Tel: +39-0321-777880 Fax: +39-0321-777959 E-mail: info@scandiesel.it Website: www.scandiesel.it Contact: Attilio Origo, Tiziana Dellera
Mizuno Marine Co Ltd 1-12-15 Meishinguchi Toyonaka-City Osaka 561-0841 JAPAN	Tel: +81-6-6863-5233 Fax: +81-6-6863-5029 E-mail: mizuno@mizuno-marine.co.jp Website: www.mizuno-marine.co.jp Contact: Nobuyuki Shimazaki
BNS KOREA Co. #183, Nokdong-ri, Oedong-eup, Gyeongju-si Gyeongsangbuk-do 780-823 KOREA	Tel: +82-54-623-1100 Fax: +82-54-623-1150 E-mail: bnskorea@empal.com Website: www.bnskoreaco.com Contact: J.H. Lee, T.Y. Kim
GR Shipping Minijos 2-207 Klaipeda 91234 LITHUANIA	Tel: +370 46 312880 Fax: +370 46 310785 E-mail: gediminas@ltap.lt Website: www.ltap.lt www.boating.lt Contact: Gediminas Ragauskas
Forwin Company Ltd, Macau Office Estrada de sete Tanques, No 1441-D Edf. Cypress Court 11-Andar-B Taipa MACAU	Tel: +853-705110 Fax: +853-705113 E-mail: forwin@macau.ctm.net
Amenkay Teknik Sdn Bhd 23-1, Jalan Medan PB 3 Seksyen 9, Bandar Baru Bangi 43650 Selangor MALAYSIA	Tel: +603-8925-6085 Fax: +603-8925-6064 E-mail: info@amenkayteknik.com Website: www.amenkayteknik.com Contact: Rafiee Ismail
Rouget Ltee Mariamen Temple Road Cap Malheureux MAURITIUS	Tel: +230-2626373 Fax: +230-2626643 E-mail: rouget@intnet.mu Contact: R Permall
Somabri 21, Boulevard Lahcen Ouidder Casablanca 20 200 MOROCCO	Tel: +212-2-2312056 / 2445014 Fax: +212-2-2445051 / 2443801 E-mail: kelfmo@casanet.net.ma Contact: Khaddach el Mostafa
The Engine Room Limited 34 Enterprise Street P.O. Box 34-0132 North Shore City 0746 Auckland NEW ZEALAND	Tel: +64-9-480-2248 Fax: +64-9-480-2258 E-mail: theengineroom@xtra.co.nz Website: www.theengineroom.co.nz Contact: Andy Winter
Univa AS Tromøyveien 26 4841 Arendal NORWAY	Tel: +47-370-62050 Fax: +47-370-62051 E-mail: kr@univa.no Website: www.univa.no Contact: Svein Rasmussen / Kåre Rosland
EIN Electromecánica e Ingeniería S.A. Altos de Panamá Torre Mcgregor Heights, T #4, PBA Panama REPUBLIC OF PANAMA	Tel: +507-676-15423 Fax: +507-265-7412 E-mail: einsa.p@gmail.com Contact: Javier Sánchez-Serrano (Distributor for PANAMA, COLUMBIA, VENEZUELA)
JCL J. Ciesielski Ltd Ul. Armii Krajowej 116/3 81-824 Sopot POLAND	Tel: +48-58-5516631 Fax: +48-58-5513966 E-mail: jcl@jcl.com.pl Contact: Jozef Ciesielski
Valoil Lda. Quinta do Valvite Toledo 2530-771 Loureinha PORTUGAL	Tel: +351-912-832420 Fax: +351-917-144098 E-mail: jbarum.valoil@mail.telepac.pt Contact: Pedro Furtado, A. Teles
OOO "SPB Marine" Office 310, 6, Vasi Alekseeva Str. St-Petersburg 198188 RUSSIA	Tel: +7-812-458-8726 Fax: +7-812-335-6820 E-mail: d.kutuzov@spbmarine.com Website: www.spbmarine.com Contact: Dmitry Kutuzov
Triton Marine Industri Pte Ltd No 7, Toh Guan Road East 04-01 Alpha Industri Building SINGAPORE 608599	Tel: +65-6773-0623 / 6272-6500 Fax: +65-6273-7292 E-mail: j_s_ang@yahoo.com / jsang1976@gmail.com Contact: J.S. Ang

OPERATING MANUAL FOR BUKH DV36ME ENGINES

Civic International Pte Ltd 38 Benoi Place Singapore 629952 SINGAPORE	Tel: +65-6861-7633 Fax: +65-6861-5069 E-mail: chee_keong_chia@civic.com.sg E-mail: civicint@singnet.com.sg Contact: Chia Chee Keong / Han Jock Kwong
Keppel Sea Scan Pte Ltd No. 44 Benoi Road Singapore 629904 SINGAPORE	Tel: +65-6863-0788 Fax: +65-6863-6960 E-mail: sherry.li@keppelseascan.com Contact: Ms Sherry Li Shaoling
Southern Marine Workshops CC 3 Carlisle Street, Paarden Eiland Cape Town, 7405 SOUTH AFRICA	Tel: +2721 5102420 Fax: +2721 5102467 E-mail: info@southernmarine.co.za Website: www.southernmarine.co.za Contact: Clive Wienand
Jiménez Conesa S.L. Puerto Pesquero s/n 04002 Almería SPAIN	Tel: +34-950-258948 / 235952 Fax: +34-950-264926 E-mail: jimenezconesa@yahoo.es Contact: Rafael Jiménez Boix
Jimenez Conesa C/. Carlos V, 25 52006 Melilla SPAIN	Tel: +34-95-2673379 / 2672678 Fax: +34-95-2673831
Náutica Toni Socias S.L. Plaza Navegación 6 07013 Palma de Mallorca SPAIN	Tel: +34-971-455641 Fax: +34-971-455890 E-mail: toni@dinatec.net Website: www.dinatec.net Contact: Antonio Socias
Industrial & Marine Development Co (Pvt) Ltd 9/3, #6, Rajakeeya Mawata Colombo 7 SRI LANKA	Tel: +94-1-685782 Fax: +94-1-685782 E-mail: imadco@sltnet.lk Contact: Kithsiri De Silva
Bosö Motor AB Box 6053 181 06 Lidingö SWEDEN	Tel: +46-876-71940 Fax: +46-873-17169 E-mail: bosomotor@gmail.com Contact: Robin Carlsson
Marindiesel Blodboksgatan 26 426 74 V. Frölunda SWEDEN	Tel: +46-31-293-058 Fax: +46-31-694-111
Min Sen Machinery Co, Ltd 777 Mahachai Road Wangburapapirom Pranakorn Bangkok 10200 THAILAND	Tel: +66-2-6211000 Fax: +66-2-6211049 / 2252877 E-mail: tawee@minsen.co.th Website: www.minsen.co.th Contact: Tawee Techatonyanon
GEPA Fiberglass Tersane Yolu, Yan Sanayi Bölgesi Aydintepe (P O Box 7) Tuzla 81700 Istanbul TURKEY	Tel: +90-216-392-9396 Fax: +90-216-392-7758 / 2064 E-mail: info@gepafiberglass.com Website: www.gepafiberglass.com Contact: Alp Özalp, President
SOLAS Marine Services Co (L.L.C.) P O Box 25445 Dubai UNITED ARAB EMIRATES	Tel: +971-4-3241-700 Fax: +971-4-3241-804 E-mail: info@solasmarine.com Contact: P S Kamath, S Prabhu
Uruguayan Marine Safety Ltd Arturo Lezama 2228 11800 Montevideo URUGUAY	Tel: +598-2-924-6025 Fax: +598-2-924-4938 E-mail: weserve@ums.com.uy Website: www.ums.com.uy Contact: Alberto Zambrana
North Jersey Marine 215 Trimble Ave. Clifton, N.J. 07011 USA	Tel: +1-973-667-1730 Fax: +1-973-667-1831 E-mail: rbainnjmdiesels@hotmail.com Contact: Bob Bain
Waterway Diesel Center Inc. P.O. Box 97 Deale, Maryland 20751-0097 USA	Tel: +1-410-867-2182 / +1-44-3871-6256 Fax: +1-410-867-3366 E-mail: jdcraven@verizon.net Contact: Davis H. Craven
Alexander / Ryan Marine & Safety Co P O Box 9363 Houston, Texas 77261-9363 USA	Tel: +1-713-923-1671 Fax: +1-713-923-1972 E-mail: sales@alexanderryan.com Website: www.alexanderryan.com
L.A. Maritime Services, Inc. 327 Lecouvreur Avenue Los Angeles, CA 90744 USA	Tel: +1-310-518-1718 Fax: +1-310-549-1122 E-mail: info@la-maritime.com Website: www.la-maritime.com Contact: Sonia L. Brown

General Terms of Sale and Delivery

1. Introduction

The terms of sale and delivery specified below shall apply to all quotations, orders and consignments unless otherwise specified in any other written agreement.

2. Quotations

Quotations shall be subject to confirmation and the goods being unsold. Bukh A/S reserves the right to change unconfirmed quotations without notice. The prices stated are exclusive of value-added tax and other duties.

3. Orders

Any order shall be confirmed in writing by Bukh A/S in order that an agreement on consignments can be considered as binding.

The order will be delivered at a confirmed price subject to price increases resulting from changes in trade conditions, duties, rates of exchange, raw material supplies and similar conditions.

Cancellation will only be accepted as per arrangement and against payment of expenses incurred.

Illustrations, dimensioned sketches, as well as the contents of leaflets, catalogues, circular letters, etc are approximate and with no binding effect.

When carrying out the order, Bukh A/S reserves the right to make any changes which are deemed necessary from a technical point of view.

4. Terms of Delivery

Delivery will be "ex works" (Incoterms 2010), unless otherwise agreed.

Bukh A/S shall not be responsible for delays or obstacles due to force majeure, for example labour conflicts, fires, currency restrictions, shortage of labour and means of transport, general scarcity of goods, restrictions on power and flaws in consignments from subsuppliers or delay in such consignments, or any other conditions beyond the influence and control of Bukh A/S as well as delay caused by the customer not having supplied sufficient technical information punctually.

If the customer fails to observe the terms stipulated for payment of the purchase price, Bukh A/S shall be under no obligation to make delivery.

Bukh A/S shall not pay any damages for delays in delivery.

5. Packaging

Packaging is included in the price of the product and will not be taken back.

6. Payment

Payment for all consignments shall be made directly to Bukh A/S, Krusaa, Denmark.

The customer shall not be entitled to withhold payment because of any counterclaims.

If payment should be effected later than the stipulated settling date, interest shall be paid on overdue payments at the rate of 1.5 per cent per month or fraction of a month. Bukh A/S reserves the right to change the rate of interest.

Any consignment shall remain the property of Bukh A/S until payment has been made in full, and the customer must keep the consignment insured against fire and damage - in case of marine plant, against sea risk - at the total new value from the date of shipment from the factory and until full payment has been effected.

7. Remedying Defects

If the consignment should prove defective, Bukh A/S undertakes during the first 24 months after the consignment has been put into service, however, not beyond 30 months from the day the consignment is reported to be ready for shipment, in the case of spare parts, however, 3 months from shipment, to remedy defects which are due to faulty design, materials or workmanship. However, the obligation to remedy defects is conditional on the operating conditions contained or provided in the agreement being observed and the consignment being used and operated correctly. Defects which are due to 1) improper storage before or during installation, 2) insufficient maintenance, 3) incorrect installation by the customer, 4) changes of the consignment carried out without the written consent of Bukh A/S, 5) incorrect or inexpedient repairs made by the customer or others, 6) normal wear or deterioration, rust, corrosion, deposits caused by water, foreign matter in pipes or the use of unsuitable oils, shall not be covered by Bukh A/S's obligation to remedy defects.

Unless otherwise stipulated, all transport and mounting of defective, repaired and replaced equipment shall be at the customer's account and risk.

Parts of the consignment which are not manufactured by Bukh A/S will only be replaced to the extent that Bukh A/S is compensated for them by the subsupplier.

Bukh A/S' liability for defects is limited to the above-mentioned obligation. Bukh A/S shall only pay damages if it is proved that the loss caused by the defect is due to gross negligence or intentional circumstances on the part of Bukh A/S. Bukh A/S shall in no circumstances be held liable for operation loss, loss of profits or any indirect damage.

8. Arbitration

Any disputes are to be settled according to Danish law by arbitration in Copenhagen according to the rules of the International Chamber of Commerce and in accordance with the Danish Act on Arbitration of 1972.