

1. Main structure

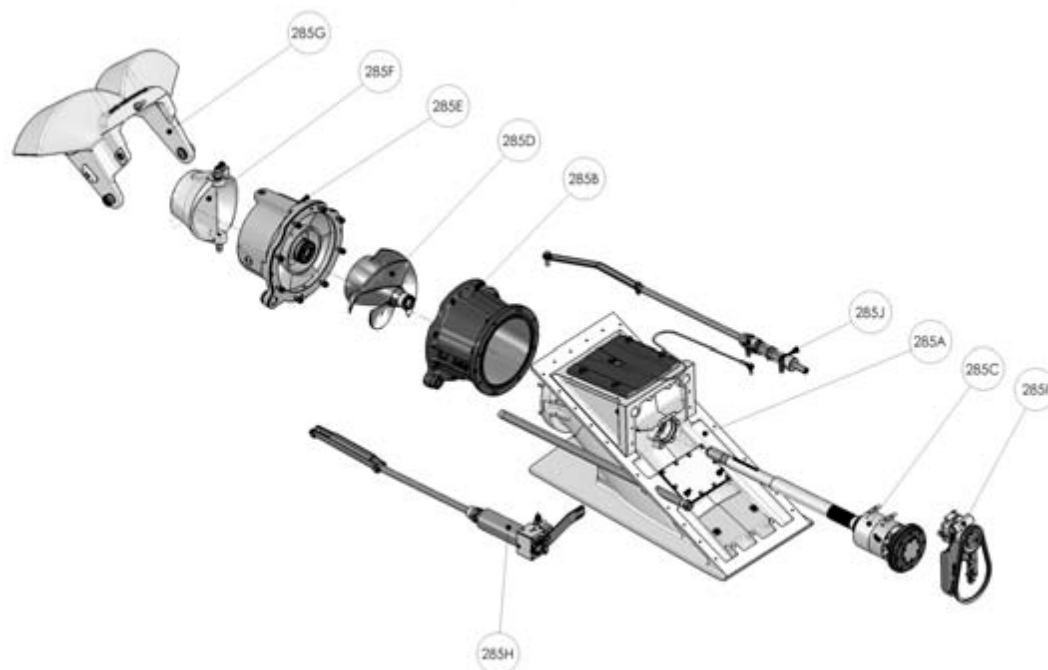

285A	Frame	285F	Steering nozzle
285B	Impeller tunnel	285G	Reversing deflector
285C	Bearing and main shaft	285H	Hydraulic cylinder
285D	Impeller	285I	Hydraulic oil pump
285E	Stator	285J	Steering cylinder

2. 285A Frame

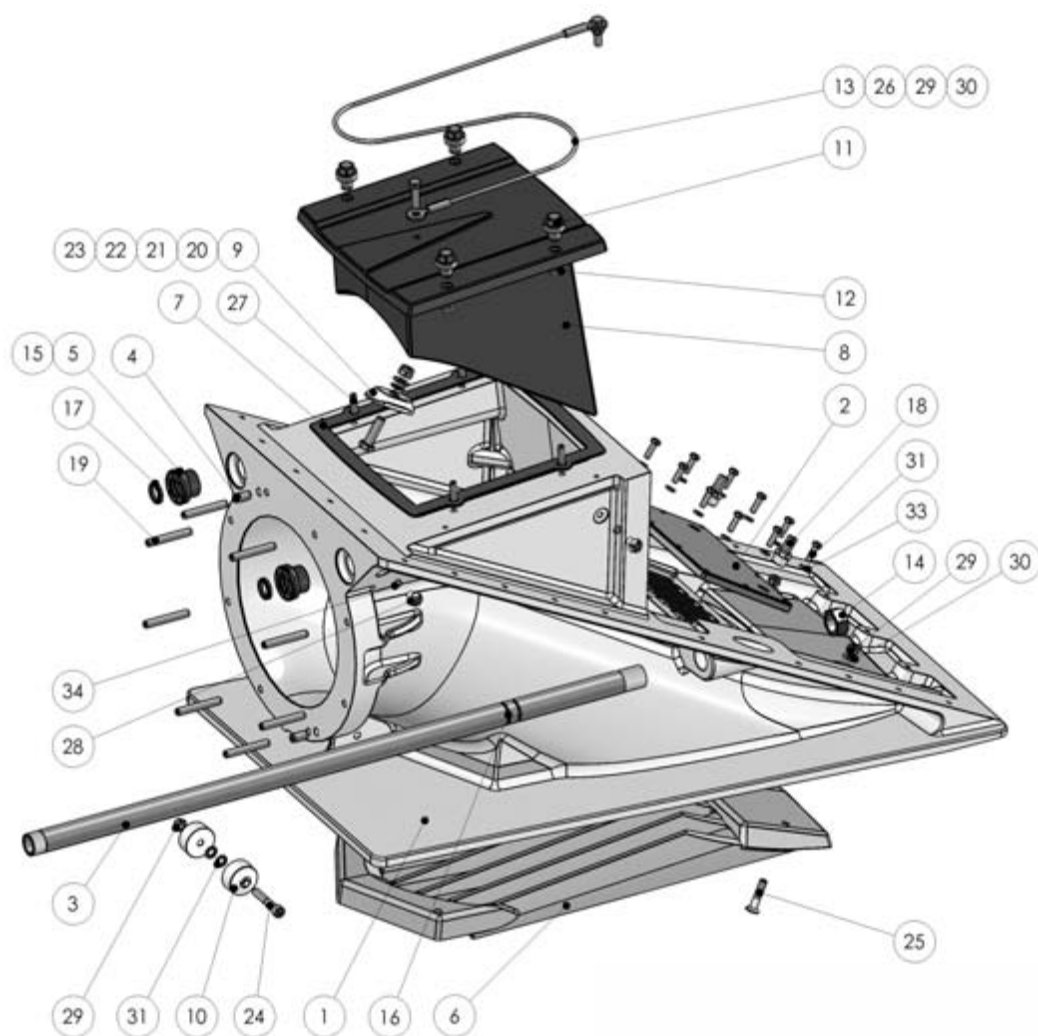

Pos.	Description	Code	Pcs
1	Frame	11110	1
2	Cooler cover	10979	1
3	Raw water pipe	11067	1
4	Dowel pin	10762	2
5	Seal sleeve	10763	2
6	Grass rake	11195	1
7	Inspection hatch seal	11177	1
8	Inspection hatch	11176	1
9	Anode	10053	1
10	Anode	10409	2
11	Screw	10822	4
12	Round wire retaining ring	10820	4
13	Wire	10916	1
14	Plug with seal	P0377	1
15	O-ring	T0000044	2

Pos.	Description	Code	Pcs
16	O-ring	T0000022	2
17	Wiper	5773	2
18	Hose fitting	P0314	2
19	Set screw M10	R05100602	8
20	Hex screw M10	R04100352	1
21	Locking nut M10	R31100002	1
22	Washer M10	R10100002	1
23	SL washer M10	R12100002	1
24	Hex socket screw M8	R01080502	1
25	Hex socket countersunk screw M8	R02080402	4
26	Hex screw M8	R04080302	2
27	Set screw M8	R05080252	4
28	Plastic plug M8	11038	4
29	Locking nut M8	R31080002	5
30	Washer M8	R10080002	4
31	Hex screw M6	R04060202	10
32	SL washer M8	R12080002	2
33	Washer M6	R10060002	10
34	O-ring	T0000008	4

The product code for the frame seal sleeve kit is P9909.

3. 285B Impeller tunnel



Pos.	Description	Code	Pcs
1	Impeller cone	11095	1
2	Hex socket screw M8	R01100452	1
3	Anode	10409	1
4	SL washer M8	R12080002	1
5	Raw water coupling	10761	1
6	O-ring	T0000260	1
7	Washer M10	R10100002	8
8	Locking nut M10	R31100002	8
9	Dowel pin	10762	2
10	Cone	10728	1

4. 285C Bearings and main shaft

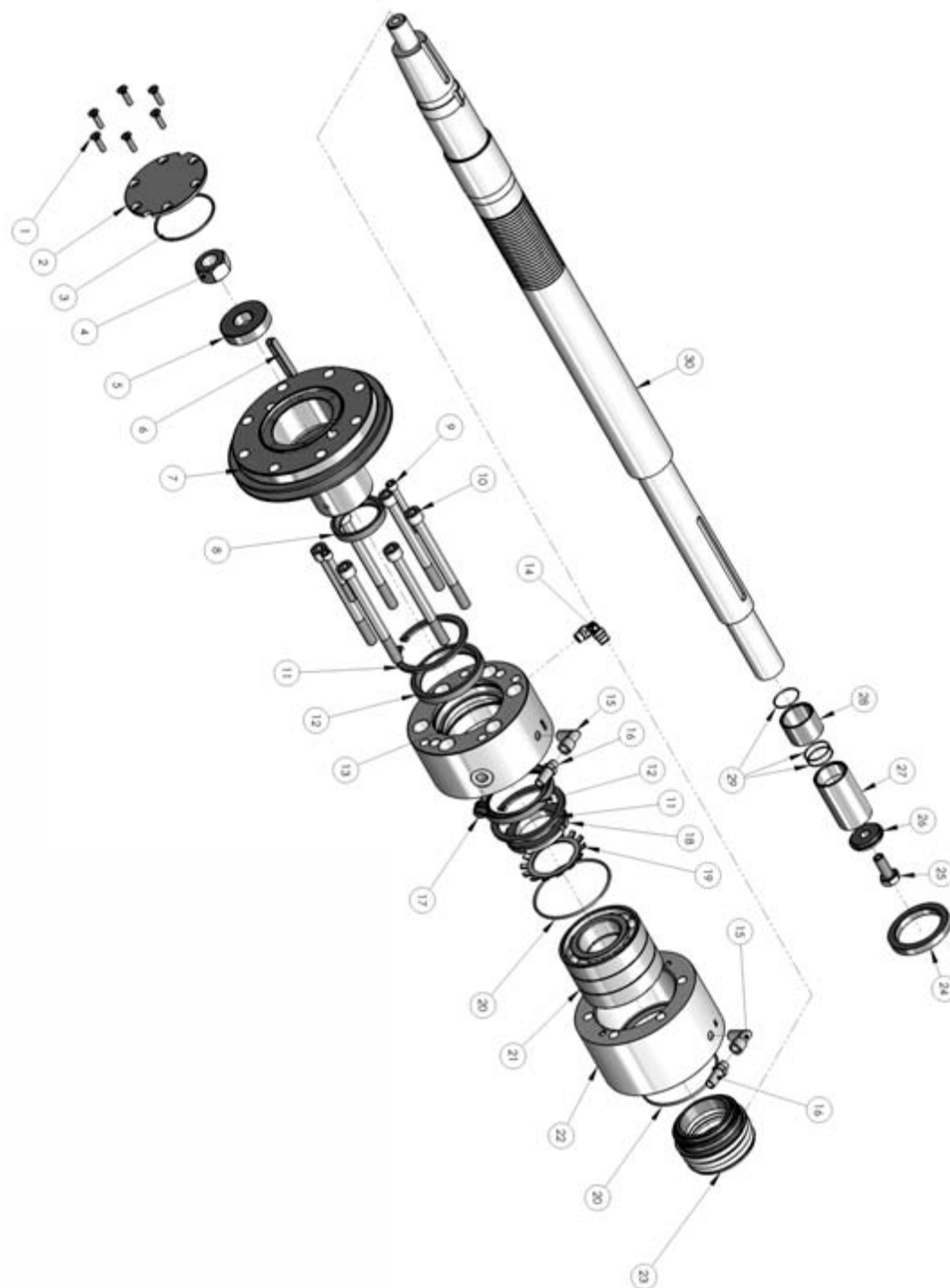

Pos.	Description	Code	Pcs
1	Hex socket countersunk screw M5	R02050202	6
2	Cover ring	11093	1
3	O-ring	T0000060	1
4	Nut M20	R30200002	1

Pos.	Description	Code	Pcs
5	Spacer	11092	1
6	Key	K0205	1
7	Drive flange	11091	1
8	Shaft seal	T425508A	1
9	Hex socket screw M6	R01060602	2
10	Hex socket screw M10	R01101202	6
11	Retaining ring	L0455	2
12	Shaft seal	T607508AS-P	2
13	Bearing housing cover	11071	1
14	Angle fitting	P0504	1
15	Angle fitting	P0502	2
16	Hose fitting	P0602	2
17	Plug	P0375	1
18	Shaft nut	L0209	1
19	Lock washer	L0313	1
20	O-ring	T0000078	2
21	Angular ball bearing	L0123	3
22	Bearing housing	11070	1
23	Mechanical seal	T5000000	1
24	Support ring	10358	1
25	Screw	10937	1
26	Locking plate	10363	1
27	Shaft sleeve	10362	1
28	Shaft sleeve	10419	1
29	O-ring	T0000025	3
30	Shaft	11072	1

4.1. 10610 Oil reservoir



Pos.	Description	Code	Pcs
1	Oil reservoir bracket	10543	1
2	Plug with magnet	P0346	1
3	Oil reservoir	10535	1
4	O-ring	T0000124	1
5	Oil reservoir cover	10536	1
6	LOD washer M5	R11050002	6
7	Spring washer M5	R13050002	6
8	Hex screw M5	R04050252	6
9	Cap	P0345	1

5. 285D Impeller

5.1. Impellers #12-3, #14-3, #15-3, #15-4 and #17-4

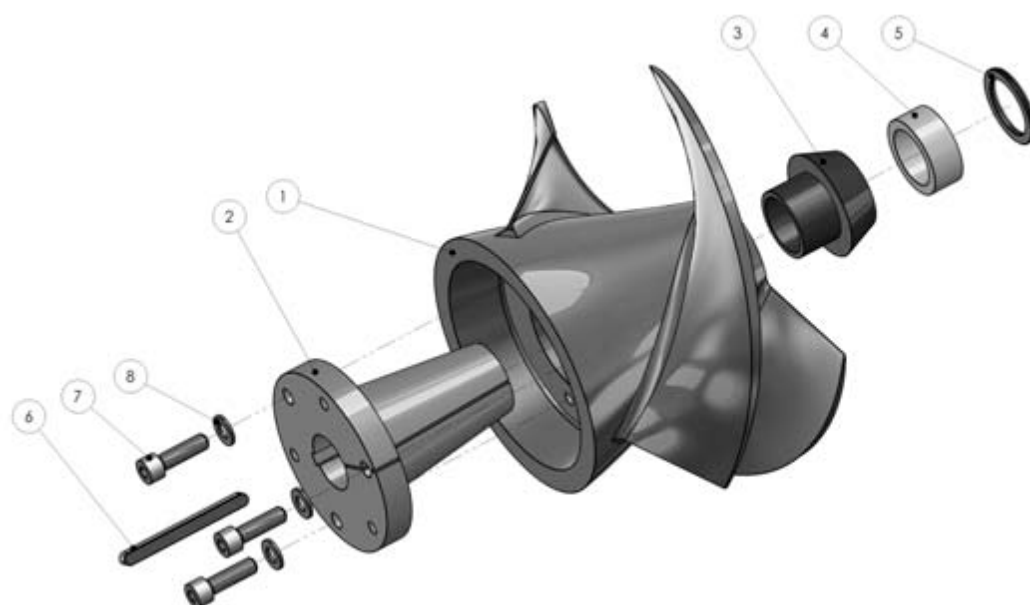

Pos.	Description	Code	Pcs
1	Impeller	*	1
2	Impeller mounting cone	10198	1
3	Isolation ring	10513	1
4	Shim ring	**	**
5	Adjuster sleeve	11166	1
6	Key	K0204	1
7	Hex socket screw M10	R01100352	3
8	Washer M10	R10100002	3

*Code is determined by impeller type

Description	Code
Impeller #12-3	10617
Impeller #14-3	10920
Impeller #15-3	10515
Impeller #15-4	10514
Impeller #17-4	11084

**Code and quantity are determined by impeller type and impeller tip clearance

5.2. Impeller #17-3

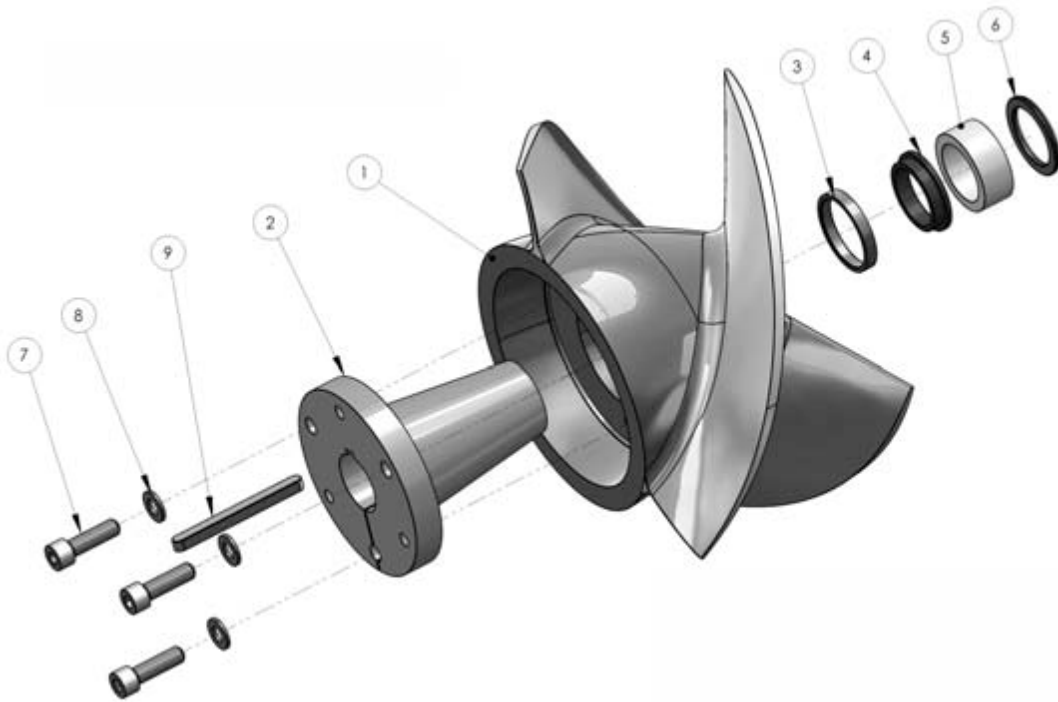

Pos.	Description	Code	Pcs
1	Impeller 17-3	10511	1
2	Impeller mounting cone	10198	1
3	Insulating ring support	10469	1
4	Isolation ring	10468	1
5	Shim ring	**	**
6	Adjuster sleeve	11166	1
7	Hex socket screw M10	R01100352	3
8	Washer M10	R10100002	3
9	Key	K0204	1

**Code and quantity are determined by impeller type and impeller tip clearance

5.3. Shim rings for impeller adjusting

Description	Code
Shim ring 0.5 mm	10421
Shim ring 1 mm	10416
Shim ring 3 mm	10420
Shim ring 5 mm	10422
Shim ring 10 mm	10423
Shim ring 20 mm	10424

5.4. Impeller, choker and steering nozzle combinations

Impeller code	Type	Choker code	Choker diameter (mm)	Steering nozzle code
10617	#12-3	11244	146	11130D150
10920	#14-3	11244	146	11130D150
10515	#15-3	11244	146	11130D150
10514	#15-4	11244	146	11130D150
10511	#17-3	11262	162	11130D167
11084	#17-4	11073	149	11130D157

6. 285E Stator

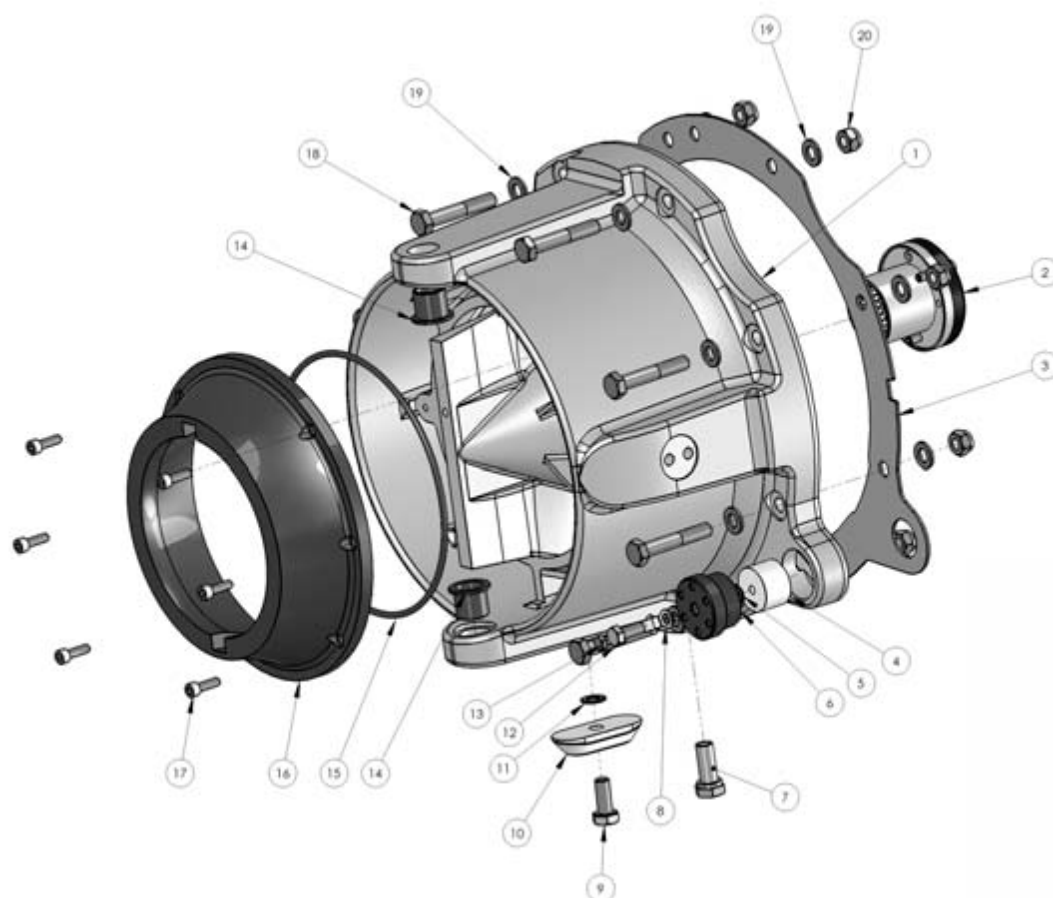

Pos.	Description	Code	Pcs
1	Stator	11060	1
2	Rear bearing housing	10857	1
3	Stator seal	11094	1
4	Anode	10441	1
5	SL washer M8	R12080002	1
6	Plug	10467	1
7	Drain plug	10546	1
8	Lead	10470	1
9	Hex screw M10	R04100252	1
10	Anode	10053	1
11	SL washer M10	R12100002	1
12	Hex screw M8	R04080202	1
13	Hex screw M6	R04060202	1
14	Compound bearing	H0403	2
15	O-ring	T0000190	1
16	Choker	*	1
17	Hex socket head screw M6	R01060202	6
18	Hex screw M10	R04100602	8

Pos.	Description	Code	Pcs
19	Washer M10	R10100002	16
20	Locking nut M10	R31100002	8

*Code is determined by choker ID and impeller type

6.1. 10857 Rear bearing housing

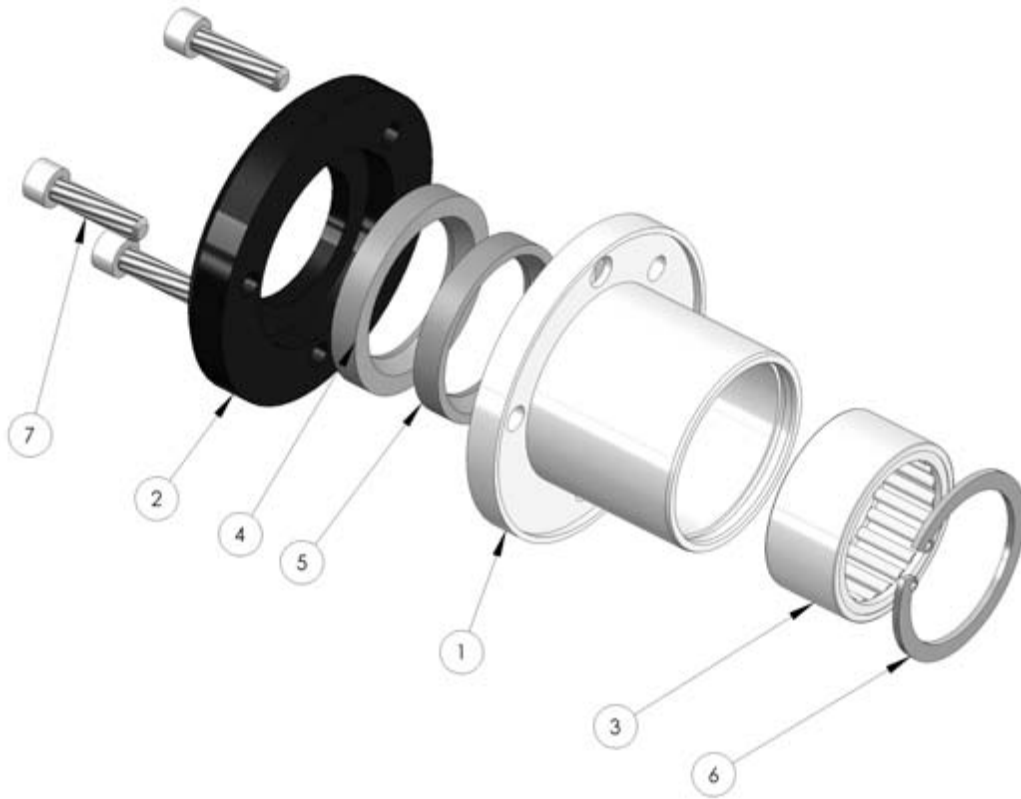

Pos.	Description	Code	Pcs
1	Rear bearing housing	10855	1
2	Back bearing housing cover	10856	1
3	Needle roller bearing	L0140	1
4	Shaft seal	T9900033AS-P	1
5	Shaft seal	T9900031	1
6	Retaining ring	L0452	1
7	Hex socket screw M6	R01060252	3

7. 285F Steering nozzle



Pos.	Description	Code	Pcs
1	Steering nozzle	11130	1
2	Joint pivot	11132	2
3	Joint pivot	11137	1
4	Anode	10409	1
5	Hex socket screw M12	R01120502	2
6	Hex socket screw M8	R01080302	1
7	SL washer M8	R12080002	1
8	Hex socket screw M6	R01060102	2

8. 285G Reversing deflector

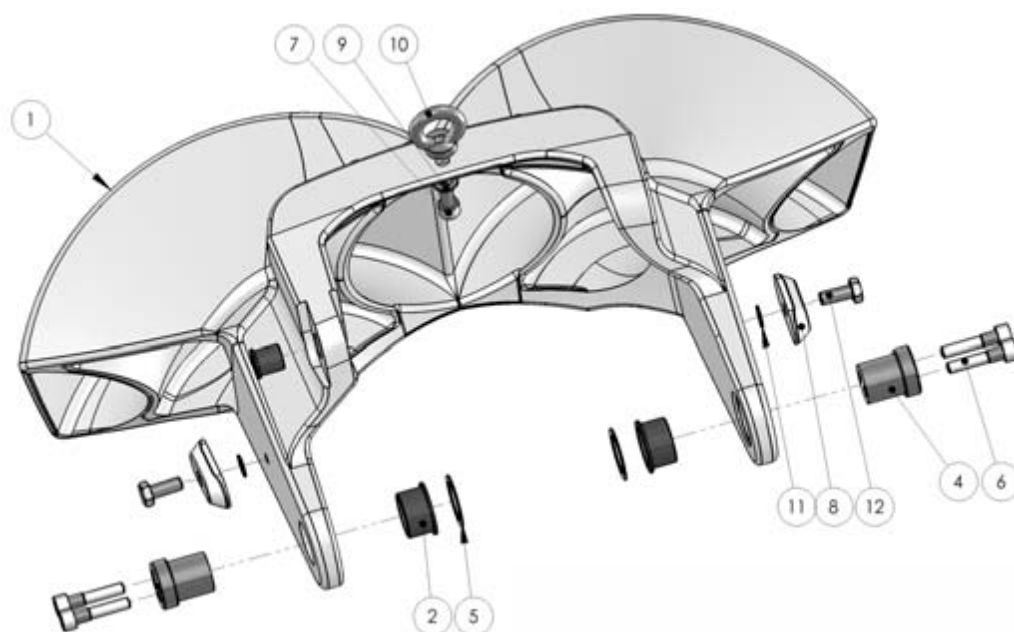

Pos.	Description	Code	Pcs
1	Reversing deflector	11099	1
2	Compound bearing	H0404	2
3	Compound bearing	H0406	1
4	Joint pin	10383	2
5	Plastic spacer	H0308	2
6	Hex socket screw M10	R01100452	4
7	Hex socket screw M10	R01100202	1
8	Anode	10053	2
9	Washer M10	R10100002	1
10	Lifting loop	R60100002	1
11	SL washer M10	R12100002	2
12	Hex screw M10	R04100252	2

9. 285H Hydraulic cylinder

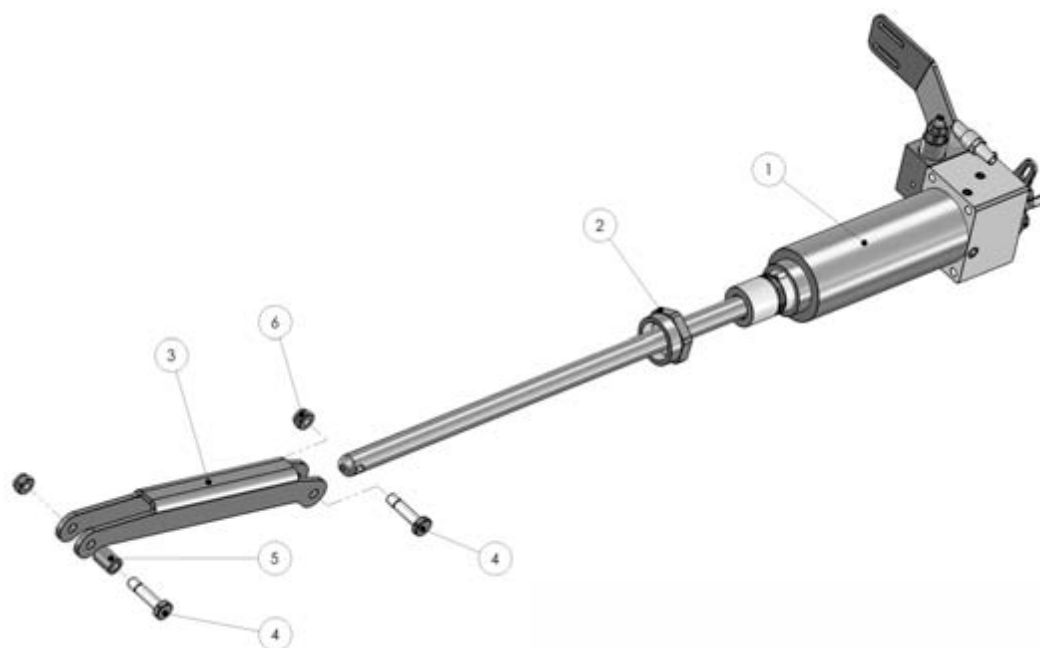

Pos.	Description	Code	Pcs
1	Hydraulic cylinder	11096	1
2	Nut	10812	1
3	Intermediate bar	11101	1
4	Joint screw	10436	2
5	Sleeve	10026	1
6	Locking nut M10	R31100002	2

9.1. 11096 Hydraulic cylinder

Pos.	Description	Code	Pcs
1	Hex socket screw M8	R01080402	1
2	Lever	10310	1
3	Locking nut M8	R31080002	1
4	Hex screw M6	R04060802	4
5	Spring washer	R13060002	4
6	Cable bracket	10208	1
7	Reduction fitting	P0367	1
8	Copper seal	P0372	1
9	Angle fitting	P0302	1
10	Hose fitting	P0307	1

10. 285I Hydraulic oil pump

10.1. 11257 Hydraulic oil pump

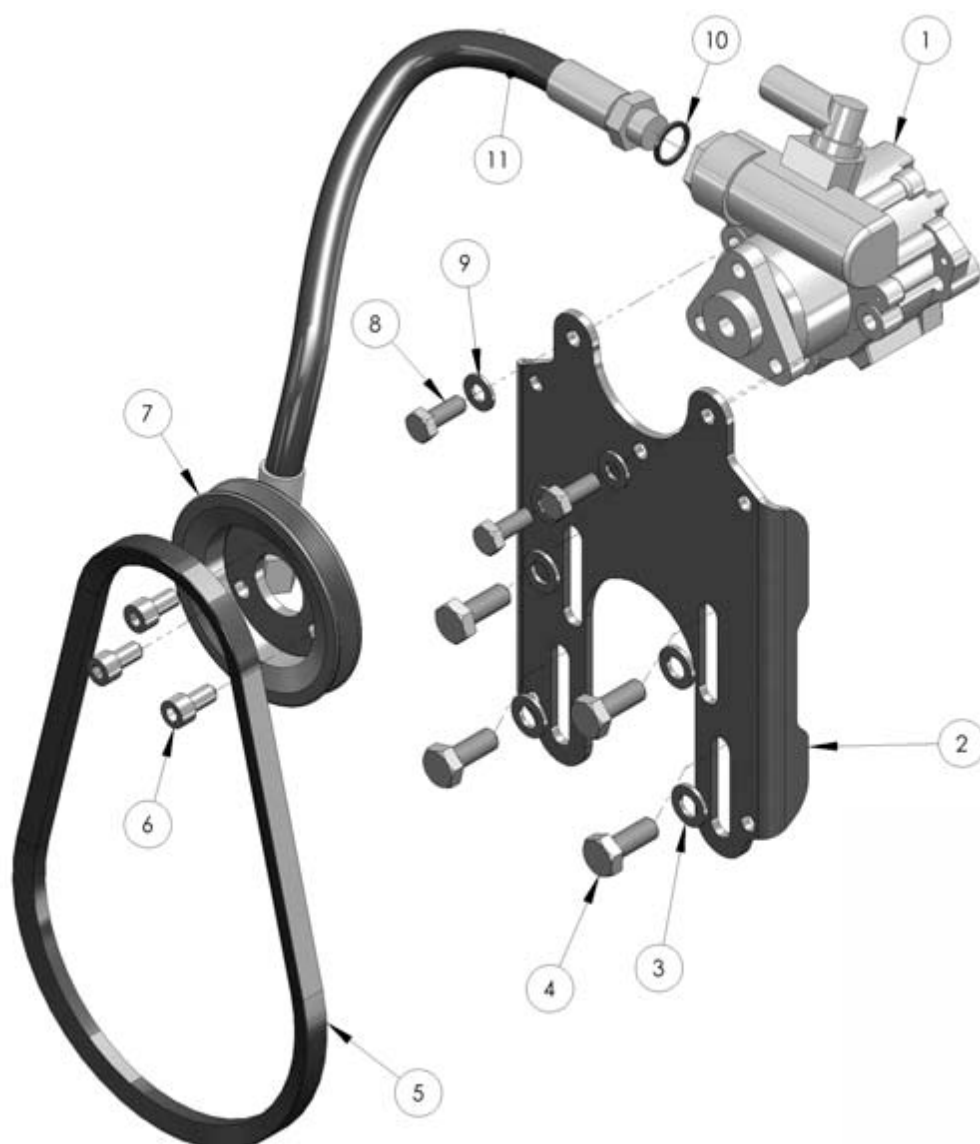

Pos.	Description	Code	Pcs
1	Hydraulic pump	5715	1
2	Oil pump bracket	10407	1
3	Washer M10	R10100002	4
4	Hex screw M10	R04100252	4
5	V-belt	5721	1
6	Hex socket screw M8	R01080162	3
7	Belt pulley	10093	1
8	Hex screw M8	R04080202	3
9	Washer M8	R10080002	3
10	Copper seal	P0341	1
11	Pressure hose	P0115	1

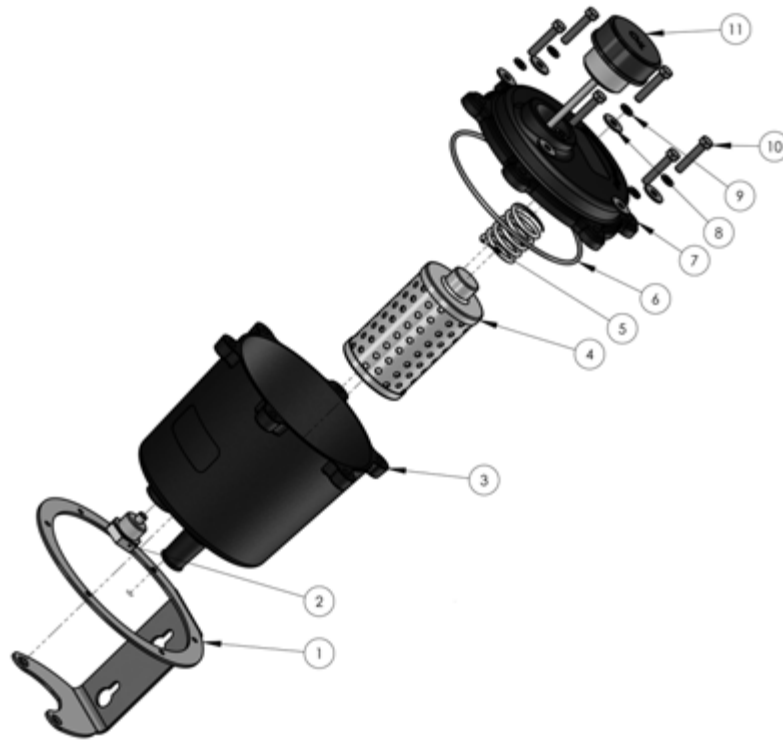
10.2. 10537 Oil reservoir

Pos.	Description	Code	Pcs
1	Oil reservoir bracket	10543	1
2	Oil plug	P0380	1
3	Oil reservoir	10535	1
4	Oil filter	10560	1
5	Spring	K0703	1
6	O-ring	T0000124	1
7	Oil reservoir cover	10536	1
8	LOD washer M5	R11050002	6
9	Spring washer M5	R13050002	6
10	Hex screw M5	R04050252	6
11	Cap	P0345	1

11. 285J Steering cylinder

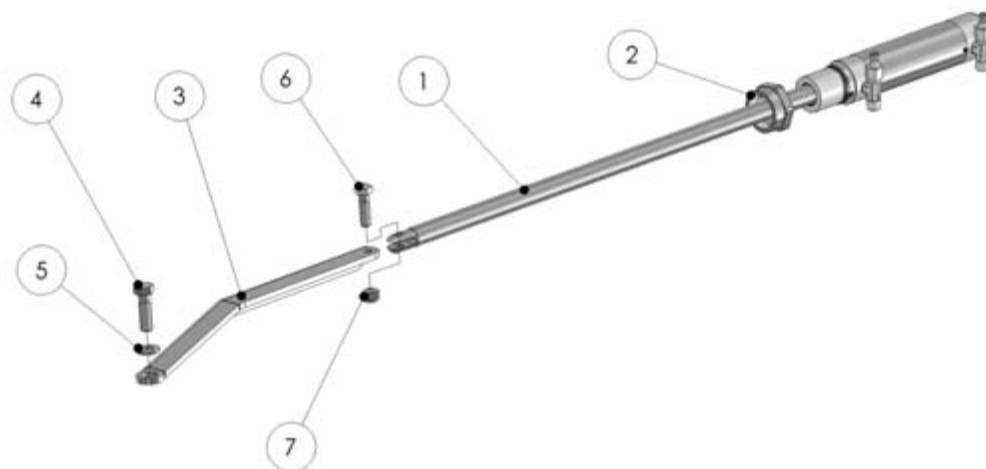

Pos.	Description	Code	Pcs
1	Hydraulic cylinder	11106	1
2	Nut	10812	1
3	Intermediate bar	1113412	1
4	Hex screw M12	R04120402	1
5	Washer M12	R10120002	1
6	Hex screw M10	R04100352	1
7	Locking nut M10	R31100002	1

The product code for hydraulic cylinder sealing and bearing set is P9908. The set includes all the seals and bearings needed for cylinder maintenance.

12. 10482 Automatic lubrication unit

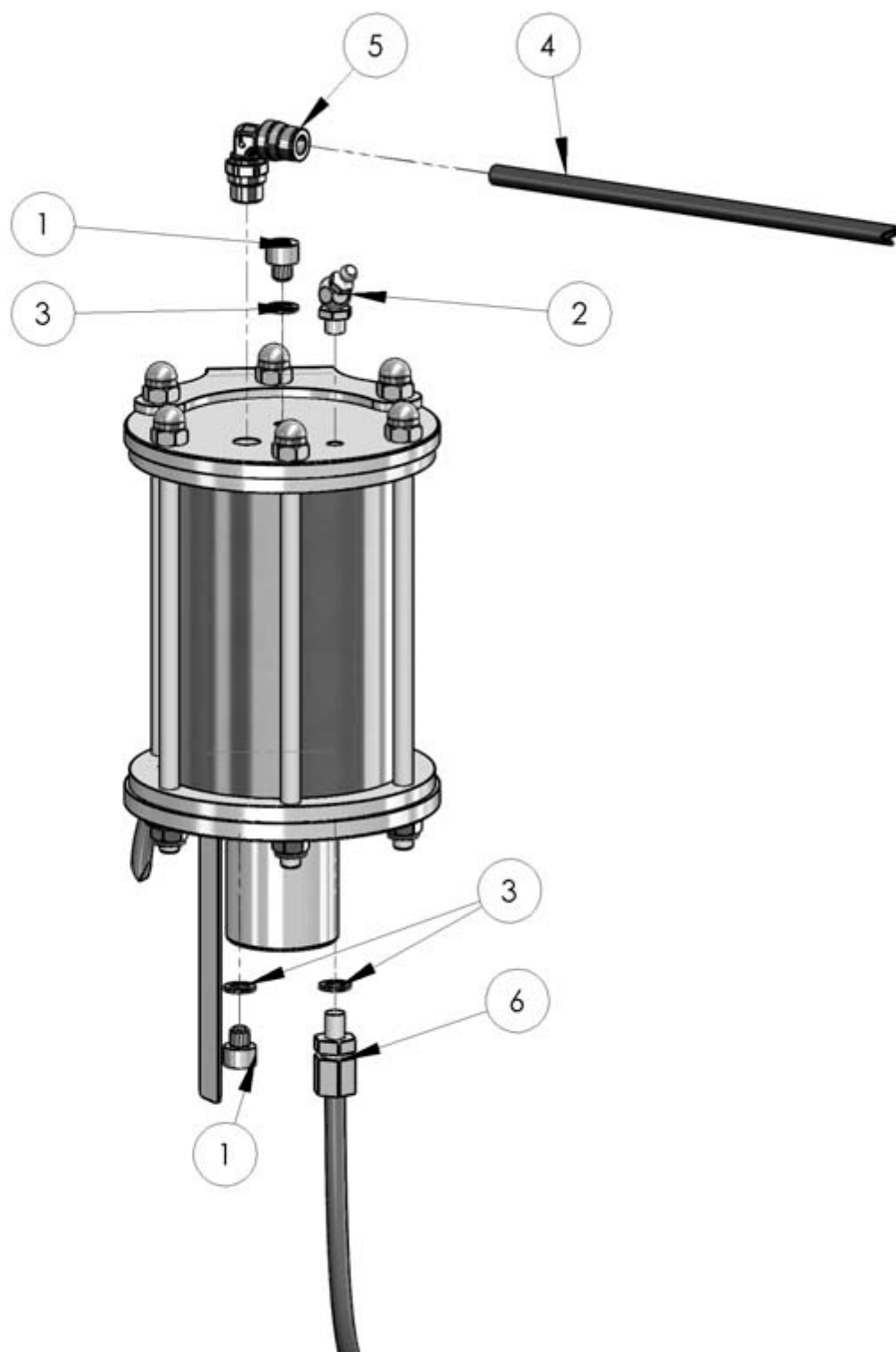

Pos.	Description	Code	Pcs
1	Hex socket screw M6	R01060062	2
2	Grease nipple	P0404	1
3	Copper seal	P0355	3

Pos.	Description	Code	Pcs
4	Hose	P0101	1
5	Angle fitting	P0504	1
6	Pressure hose	P9906	1

13. Installation templates

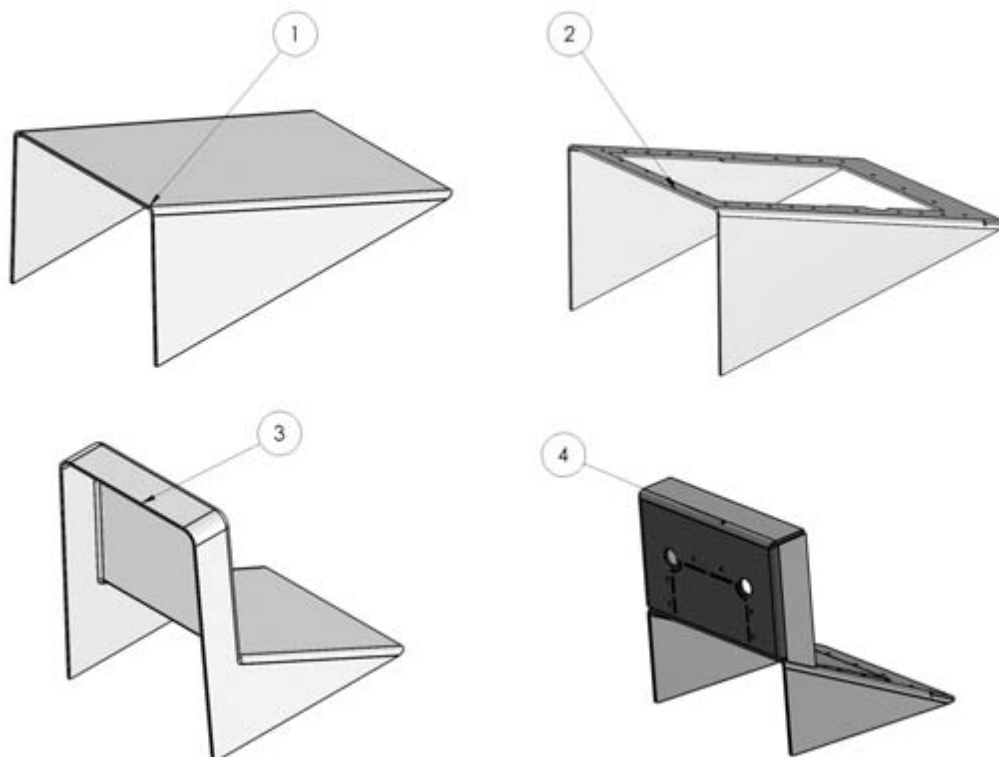

Pos.	Description	Code
1	Installation template GRP, short tail	11065
2	Installation template aluminium, short tail	11082
3	Installation template GRP, long tail	11066
4	Installation template aluminium, long tail	11184

